

PNV-100-LF-R34

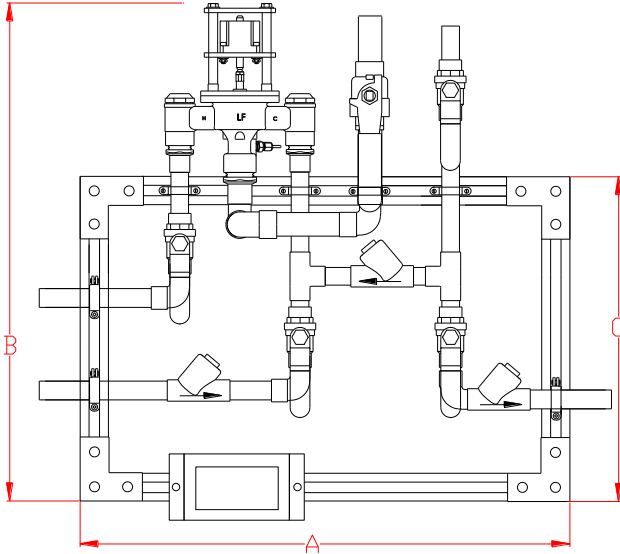

$A = 28 \pm 4''$ $B = 28'' \pm 4''$
 $C = 18'' \pm 4''$

NOTE: Options will change dimensions

STANDARD CONTROL BOX



WARNING: This product can expose you to chemicals including lead, which is known to the State of California to cause cancer. For more information, go to www.P65Warnings.Ca.gov

NEW "ENHANCED FEATURE SET" CONTROL BOX

SEE SELECTABLE OPTIONS PAGE 2



This product meets Low Lead requirements of wetted surface area containing less than 0.25% lead by weight

Product is non-cancellable and non-returnable from date of order with factory. Signed submittal required with purchase order.

- Digital Mixing Valve with 3/4" inlet angled check stops, 1" Outlet and RTD Sensor, 3/4" return piping assembly
- 3/4" inlets, 1" outlet (19mm X 25mm), copper tubing
- Valve controls at times of no use, 0.0 GPM**
- Maximum operating pressure: 125 PSIG (860 KPA)
- Controls water temperature to +/- 2°F in accordance with ASSE 1017
- Controls water temperature to +/- 2°F during times of low / no system demand
- Self-Balancing, do not need to adjust or balance recirculation
- Self-Cleaning, daily shuttle sweep keeps shuttle free of debris
- Automatic Hot/ Cold Water shutoff upon cold/ hot water inlet supply failure
- Alerts user when unit requires maintenance
- User programmable set point range between 65°F and 180°F
- Simple/intuitive user commissioning and setup
- Displays outlet temperature
- UL Listed control box and 120V plug in power supply with 6' cord
 - Option for Backup Uninterruptable Power Supply in the event of primary power loss w/ approx. two hours run time
- Factory assembled and tested

****NOTE:** The valve will maintain temperature with 0.0 GPM flow from the domestic hot water loop when properly installed near the hot water source with a continuously operating recirculation pump at 2.5 GPM.

OPTIONS:

- ___ **BPS** – Back-up Power Supply, uninterruptable power supply with up to 2 hours run time in case of primary power loss
- ___ **R1** – Return line size of 1" in place of standard 3/4"

Valve is ASSE 1017 Certified



Valve is CSA Certified



Valve electronics are UL Certified



1360 Elmwood Avenue, Cranston, RI 02910 USA

Phone: 401.461.1200 Fax: 401.941.5310

Email: info@leonardvalve.com

Web Site: <http://www.leonardvalve.com>

PNV-CONTROLLER OPTIONS

Standard Controller 1.0 Version



A = 6" B = 4"
Depth = 1-3/4"

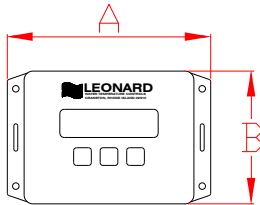

STANDARD CONTROLLER:

_____ **1.0** – See PAGE 1 for info

ENHANCED CONTROLLER OPTIONS:

_____ **2.0** – Enhanced Proton Controller with Programmable Disinfection Mode

Options:

- _____ **3T**– Three Additional Temperature Sensors for Monitoring of Inlet Hot, Inlet Cold, and Return Temperatures
- _____ **REL** – 5 Relay Contacts that Switch during Alarm State
 - Helpful for Remote Alerts Within Building to Assist Maintenance and Service Personnel
 - 5 Unique States:
 - Loss of Power
 - Broken Temperature Probe
 - “Out of Range” Temperature ($\pm 10^{\circ}\text{F}$)
 - Motor Connectivity and Operation
 - Maintenance (Service Required) @ $< 90\%$ Full travel

Enhanced Controller 2.0, 2.5, 3.0 Versions



A = 8" B = 4-3/4"
Depth = 1-1/4"

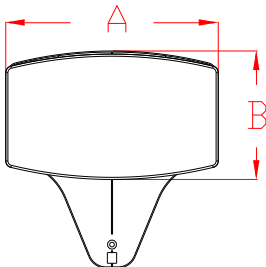

_____ **2.5** – Enhanced Proton Controller including all of 2.0 as well as BACnet MS/TP Connection which provides ability to serve up all data to BMS system

Options:

- _____ **3T** – Three Additional Temperature Sensors for Monitoring of Inlet Hot, Inlet Cold, and Return Temperatures
- _____ **REL** – 5 Relay Contacts that Switch during Alarm State (as shown above)

_____ **3.0** – Enhanced Proton Controller including all of 2.5 as well as all items below as standard,

- WiFi – Wifi enabled
- 3T - 3 Additional Temperature Sensors for Monitoring of Inlet Hot, Inlet Cold and Return Temperatures
- REL - 5 Relay Contacts that Switch during Alarm State

**AVAILABLE ON 3.0 \approx 2nd Quarter 2023
ASSE LISTING ON 3.0 PENDING



1360 Elmwood Avenue, Cranston, RI 02910 USA
Phone: 401.461.1200 Fax: 401.941.5310
Email: info@leonardvalve.com
Web Site: <http://www.leonardvalve.com>

Leonard Valve Company reserves the right of product, or design modifications without notice or obligation.

PRESSURE DROP

5	⑩	⑮	⑳	25	30	35	40	45	50	PSI
.3	.7	.97	1.4	1.7	2.1	2.4	2.8	3.1	3.4	BAR
17	25	28	32	36	39	43	45	48	51	GPM
64	95	106	121	136	148	163	170	182	193	l/min

HIGH TEMPERATURE FIXTURES (IF APPLICABLE)

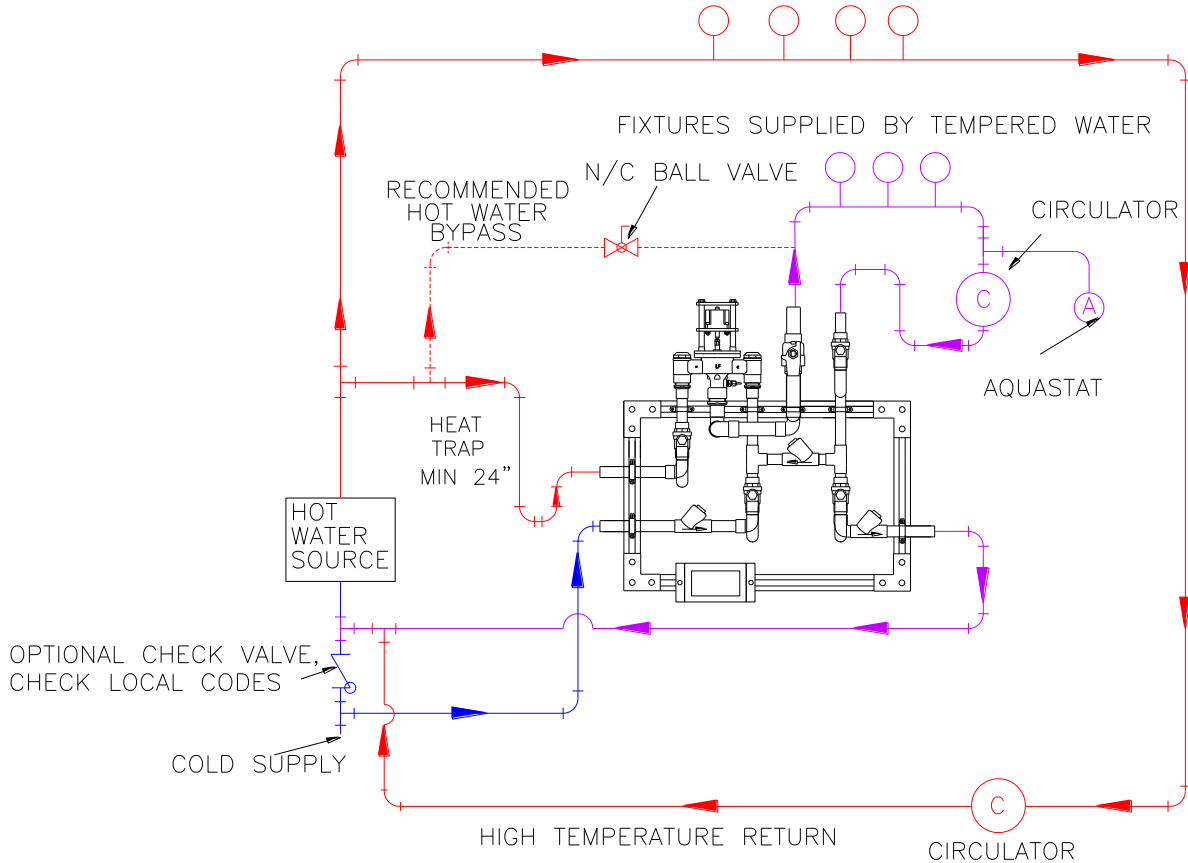

CAUTION! All thermostatic water mixing valves have limitations. They will NOT provide the desired accuracy outside of their flow capacity range. Consult the Flow Capacity Chart and DO NOT OVERSIZE. Minimum flow must be no less than as indicated.

NOTE: Flow rates will vary depending on existing field conditions. Leonard Valve Company always recommends using CASPAK® sizing software for proper valve sizing and model number applications.

Engineer's Approval

Job # _____

Arch/Eng. _____

Contractor _____

Note: The models shown represent Leonard Products which are believed to be equivalent in type and function to items specified. Leonard Valve Company is not responsible for errors or omissions due to differences in interpretations of information provided.

Note: Leonard Valve Company reserves the right of product, or design modifications without notice or obligation.



1360 Elmwood Avenue, Cranston, RI 02910 USA

Phone: 401.461.1200 Fax: 401.941.5310

Email: info@leonardvalve.com

Web Site: <http://www.leonardvalve.com>