

EMERGENCY MIXING VALVES

ECO-MIX™

Cabinet Assembly for Eye/Face Wash Units
2-10 GPM (7.6-34 l/min) flow rate
up to 45 PSI (3.1 bar) system pressure drop
TA-300-LF-STSTL-EXP

ASSE 1071 Certified 

CSA Certified 

This product is certified to meet Low Lead requirements of wetted surface area containing less than 0.25% lead by weight

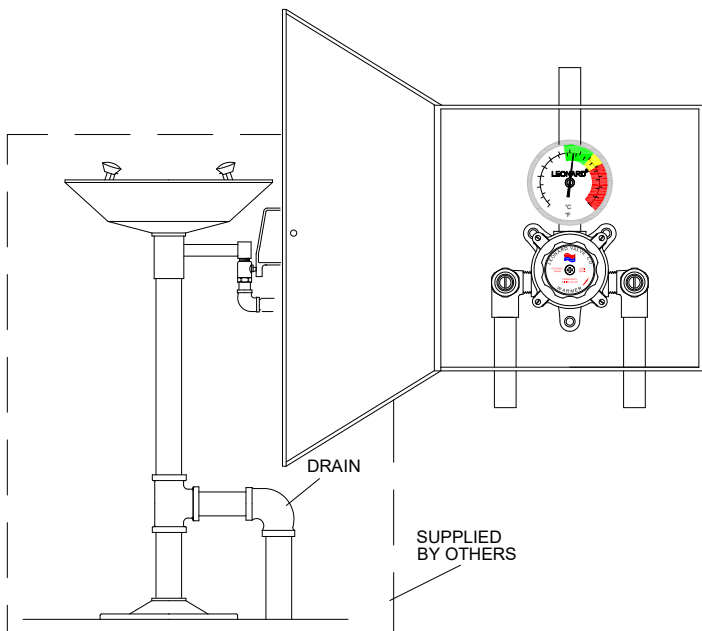

TA-300-LF-_____ **EMERGENCY WATER MIXING VALVE**

- DURA-trol® solid bimetal thermostat directly linked to valve porting to control the intake of hot and cold water and compensate for supply temperature and pressure fluctuations. DURA-trol® is highly responsive and cannot be damaged by extremes in temperature.
- Thermostatic Mixing Valve can be set to the correct temperature for the application.
- Locking temperature regulator to prevent accidental movement set for 85°F (29°C)
- Mixing valve will close down on failure of cold water supply
- Mixing valve with special internal cold water bypass capable of 4 GPM (15 l/min) @ 30 PSI (2.1 Bar) upon failure of hot water supply.
- Maximum operating pressure: 125 PSI (860 KPA)
- Adjustable high temperature limit stop * set for 90°F (32°C)
- Integral wall support
- Threaded pipe ½" bottom inlets
- Threaded pipe ½" top outlet
- Dial thermometer (range 0 to 140°F, -10 to 60°C)
- Rough bronze finish
- Exposed stainless steel cabinet with hinged door and cylinder lock
- Angle checkstops on inlets
- Compliance.....ANSI Z358.1

Engineer's Approval

Job # _____

Arch/Eng. _____

Contractor _____

OPTIONS:

- ___ SUFFIX BWE REC- Steel cabinet, baked white enamel recessed
- ___ SUFFIX STSTL REC- Stainless Steel recessed cabinet
- ___ SUFFIX BWE EXP- Exposed cabinet, baked white enamel
- ___ SUFFIX STSTL EXP- Exposed cabinet, Stainless steel
- ___ SUFFIX CP- Chrome plated finish (threaded pipe inlets & outlet)
- ___ SUFFIX TOP- Top inlets
- ___ SUFFIX VIEW- View port in door (NOT AVAILABLE WITH IT OPTION)
- ___ SUFFIX IT- Inlet thermometers, (NOT AVAILABLE WITH TOP OPTION)



WARNING: This product can expose you to chemicals including lead, which is known to the State of California to cause cancer. For more information, go to www.P65Warnings.Ca.gov

CAUTION! All thermostatic water mixing valves have limitations. They will NOT provide the desired accuracy outside of their flow capacity range. Consult the Flow Capacity Chart and DO NOT OVERSIZE. Minimum flow must be no less than as indicated.

*NOTE: A limit stop, set for 90°F (32°C), is simply a mechanical setting to prevent excessive handle rotation. If incoming water is hotter than 135°F (57°C), the temperature of the factory test, the valve when turned to full HOT may deliver water in excess of 90°F and the limit stop MUST BE RESET BY THE INSTALLER



1360 Elmwood Avenue, Cranston, RI 02910 USA
 Phone: 401.461.1200 Fax: 401.941.5310
 Email: info@leonardvalve.com
 Web Site: <http://www.leonardvalve.com>

EMERGENCY WATER MIXING VALVE FOR EYE/FACE WASH

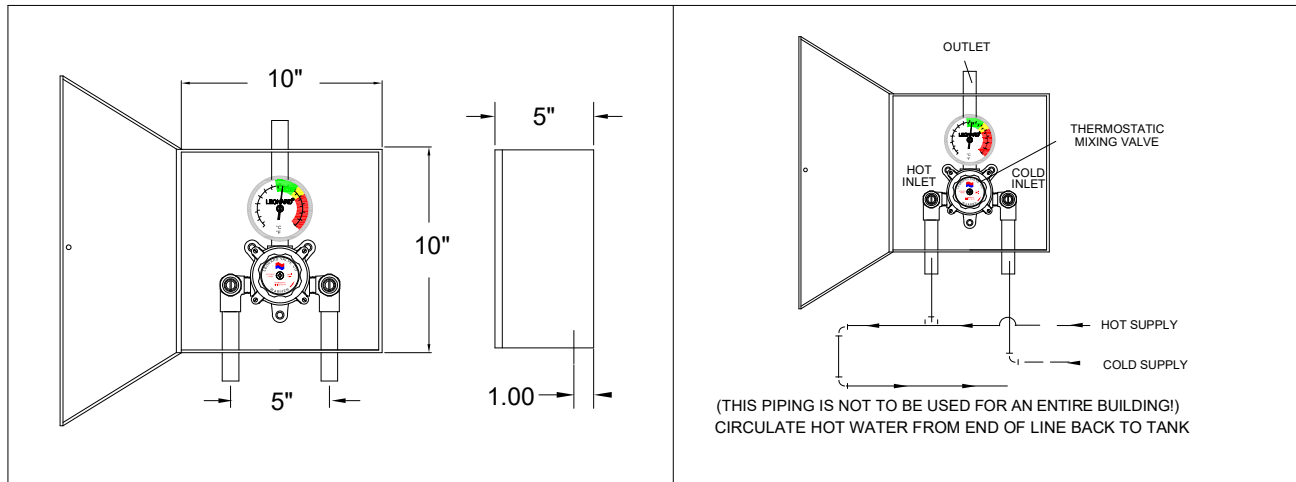

CAUTION! It may be necessary to recirculate the tempered water to the eye/face wash should the piping be exposed to excessive hot or cold conditions. Consult factory for proper piping.

FLOW CAPACITIES

MODEL	IN	OUT	MINIMUM FLOW (GPM) L/MIN	INTERNAL COLD WATER BY-PASS MINIMUM	PRESSURE DROP									PSI BAR
					5	10	15	20	25	30	35	40	45	
TA-300-LF	1/2"	1/2"	2.0	4	2.0	2.7	3.5	4.5	5.5	6.5	7.5	8.5	9.0	GPM
			7.6	15	7.6	10	13	17	21	25	28	32	34	L/MIN
MAXIMUM FLOW CAPACITY														

The Emergency eye/face wash Mixing Valve shall control and maintain the temperature of the water to the station. Unit shall be self contained and include a thermostatic water mixing valve, a dial thermometer on the outlet, angle checkstops, wall mounting bracket, piping and fittings factory assembled and tested, top or bottom inlets and top outlet, unit set for 85°F (29°C) and a maximum temperature of 90°F (32°C). Unit must be able to be set to the correct temperature for the specific contaminant but must be locked in place to prevent changing of the temperature by accident. Unit must be checked weekly for performance in conjunction with the requirements of ANSI Z358.1. Unit shall be able to flow a minimum flow of 4 GPM (15 l/min) at 30 PSI (2.1 Bar).

WARNING! IT IS THE RESPONSIBILITY OF THE SPECIFIER TO DETERMINE THE DELIVERED WATER TEMPERATURE TO EACH SAFETY FIXTURE. A COMFORTABLE RANGE IS 60°F TO 90°F (15° TO 32°C). IN CIRCUMSTANCES WHERE A CHEMICAL REACTION IS ACCELERATED BY WATER TEMPERATURE, A MEDICAL ADVISOR SHOULD BE CONSULTED FOR THE OPTIMUM TEMPERATURE FOR EACH APPLICATION.

Specifications are subject to change without notice!

CAUTION! All thermostatic water mixing valves have limitations. They will NOT provide the desired accuracy outside of their flow capacity range. Consult the Flow Capacity Chart and DO NOT OVERSIZE. Minimum flow must be no less than indicated.



1360 Elmwood Avenue, Cranston, RI 02910 USA

Phone: 401.461.1200 Fax: 401.941.5310

Email: info@leonardvalve.com

Web Site: <http://www.leonardvalve.com>