

INSTALLATION ADJUSTMENT SERVICE

TYPE TM-15, TM-20

(As furnished with models TM-554, TM-356, TM-356-W/HA, TM-186-5015-PRV, 8015, 12520, 15020)

IMPORTANT! Provide valve serial number when ordering parts!!

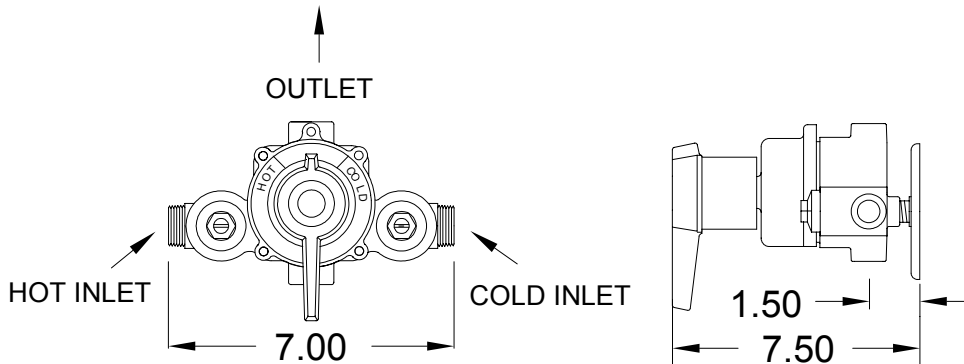

INSTALLATION

1. Valve should be installed at a location where it can easily be cleaned, adjusted or repaired.
2. The inlets are clearly marked on the valve body casting. Connect the hot water into the inlet marked "H" and cold water into the inlet marked "C."
3. A shutoff valve must be installed on the outlet pipe. Type TM valves do not have a built-in shutoff.
4. Use solder or pipe cement sparingly. Supply pipes should be flushed before the valve is connected. Flush outlet pipe and valve as soon as it is connected.

**Maximum Operating Pressure 125PSI (860 KPA)
for Hot and Cold Water.**



CAUTION



All thermostatic water-mixing valves have limitations. They will not provide the desired accuracy outside of their flow capacity range. Consult the capacity chart on page 6. Minimum flow must be no less than as shown.

REMEMBER! THIS IS A CONTROL SYSTEM WHICH MUST BE CLEANED AND MAINTAINED ON A REGULAR BASIS (SEE MAINTENANCE GUIDE AND RECORD MGR-1000).

1360 Elmwood Avenue, Cranston, RI 02910 USA

Phone: 401.461.1200 Fax: 401.941.5310

Email: info@leonardvalve.com

Web Site: <http://www.leonardvalve.com>

ADJUSTMENT AND SERVICE

Leonard Type TM Thermostatic Water Mixing Valves are simple in design and may be easily cleaned, adjusted and repaired. If the installation is accessible, servicing may be completed without disconnecting the valve.

NOTE: Thermostatic Water Mixing Valves are REGULATING mechanisms, which must be regularly maintained to provide best performance. Frequency of cleaning depends on quality of local water conditions and usage. (See Maintenance Guide and Record MGR-1000).

TO RESET ADJUSTABLE HIGH TEMPERATURE LIMIT STOP:

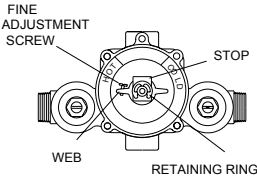

1. While valve is running, remove SNAP CAP, SCREW & WASHER. Remove POINTER, RETAINING RING, & STOP
2. Temporarily place POINTER on the spline rod. turn LEFT for warmer temperature, turn RIGHT for cooler temperature. When valve is delivering warmest temperature of 120°F (49°C) or lower, remove the pointer.
3. Replace STOP on the spline rod so that its LEFT edge is resting on the fine adjustment screw on the LEFT SIDE OF THE COVER.
4. Replace stop retaining ring.
5. Turn fine adjustment screw if necessary (clockwise for slightly HIGHER temperature, counter clockwise for slightly LOWER temperature).
6. Replace POINTER so that it is pointing to the extreme HOT position. The new maximum temperature has now been set. Test this temperature by holding a thermometer under the flow of water to be certain it is as desired.

WARNING

WARNING! This Thermostatic Mixing Valve has an adjustable high temperature limit stop which must be checked. If temperature is too high, the installer **MUST RESET** stop immediately. Always check the temperature of the mixed water when the lever handle is turned to full **HOT**. Excessively hot water is **DANGEROUS AND MAY CAUSE SCALDING!**

The high temperature limit stop is factory set at approximately 120°F (49°C) with an incoming hot water supply temperature of 150°F (65°C). If the incoming hot water on the job is higher than 150°F, the valve when turned to full hot will deliver water in excess of 120°F and the high temperature limit stop **MUST BE RESET BY THE INSTALLER.**

TROUBLESHOOTING INSTRUCTIONS

PACKINGS & GASKETS	<ol style="list-style-type: none"> 1. Leak at pointer rod. 2. Leak between valve cover and base. 	PARTS REQUIRED: REPAIR KIT 1/M20 (PACKINGS & GASKETS)
PORT SLEEVE ASSEMBLY	<ol style="list-style-type: none"> 3. Valve delivers either all hot or all cold water, or will not mix consistently. 	REPAIR KIT R/M20 (REBUILDING KIT) OR M20-1-8B BRIDGE ASSEMBLY
THERMOSTAT GROUP	<ol style="list-style-type: none"> 4. After cleaning or replacing port sleeve assembly, valve will not hold temperature. 	REPAIR KIT R/M20 (REBUILDING KIT) OR M20-G2 THERMOSTAT GROUP
CHECKSTOPS	<ol style="list-style-type: none"> 5. Hot water bypass into cold line. 6. Supplies cannot be shut off completely. 7. Leak at checkstop bonnet. 	REPAIR KIT#4/M20 (CHECKSTOP KIT)

SEE PAGE 5 FOR COMPLETE PARTS BREAKDOWN, PARTS KITS

*Check for significant variations in outlet flow. Thermostatic valves will NOT provide the desired accuracy outside of their flow capacity range. Minimum flows must be no less than shown (see Flow Capacities, page 6).

If installed on a circulated hot water system, make certain the valve is piped according to Leonard Required Methods of Piping (see page 3).

REMEMBER! THIS IS A CONTROL DEVICE WHICH MUST BE CLEANED AND MAINTAINED ON A REGULAR BASIS. (SEE MAINTENANCE GUIDE AND RECORD, MGR-1000).

REQUIRED METHODS OF PIPING TM VALVES (RECIRCULATED HOT WATER SYSTEMS)

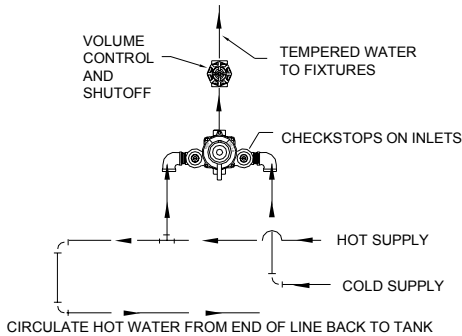

(THIS PIPING IS NOT TO BE USED FOR AN ENTIRE BUILDING!)

METHOD #1

Required when hot water in the 140°F (60°C) range is to be circulated to a master mixer or individual thermostatic mixing valves which are a substantial distance from the hot water source. It is used primarily in a building with several risers, with tempered water in each riser controlled by a separate master mixer. NOTE: The engineer must determine maximum distance which can be run, i.e. maximum allowable time for hot water to reach user with one shower head operating, based upon code requirements and/or good practice.

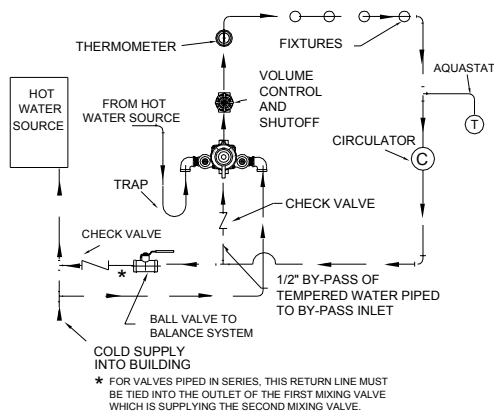

(THIS PIPING IS NOT TO BE USED FOR MORE THAN ONE BUILDING!)

METHOD #2

Required when tempered water in the 120°F (49°C) range is to be circulated through the entire building, to maintain tempered water at each fixture. The function of the 1/2" by-pass is to allow the recirculated water to pass through the mixing valve during periods of no draw without entering the hot water source to avoid being reheated. The ball valve allows the system to be properly balanced. The secondary by-pass loop helps reduce the buildup of undesirable hot water in the primary system, and **MUST NOT** be omitted. See set-up instructions below.

METHOD #2 SET-UP INSTRUCTIONS

Before any attempt is made to adjust this system, be sure the temperature of the hot water at the source is properly set and maintained.

1. Be sure system is piped in accordance with Method #2.
2. Open enough showers/lavs to cover the minimum requirements of the mixing valve installed (see Flow Capacities, page 6). Note: The minimum flow requirements apply only to the mixing valve and not to the flow of the circulator.
3. Set mixing valve to the desired temperature, (note Warning Tag attached to the pointer of the valve).
4. Shut off all showers. Note: At this point, be sure NO water is being drawn through any fixture until the temperature in the recirculated line has been set.
5. Open the ball valve approximately 1/2 way and start the circulator.
6. Observe the temperature until it stabilizes.
7. Close the ball valve slightly if the temperature is too hot, or open if it is too cold and again let the temperature stabilize. Repeat until the desired recirculated temperature is set. Open the ball valve approximately 1/2 way and start the circulator.

WARNING: THIS PIPING METHOD WILL NOT PERFORM EFFECTIVELY IF THE VALVE IS OVERSIZED. MINIMUM FLOWS ARE SHOWN ON FLOW CAPACITIES CHART, PAGE 6. FOR ESTIMATING MAXIMUM HOT WATER DEMAND, CONSULT LEONARD CASPAK® PLUS SIZING PROGRAM.

DO NOT CONFUSE THE MINIMUM FLOW REQUIREMENTS OF THE MIXING VALVE WITH PROPER SIZING OF THE CIRCULATOR.

INSTRUCTIONS FOR DISMANTLING VALVE (DWG. 1)

1. Remove pointer/(handle)(MU-5D). Shut off hot and cold supplies to valve (use screwdriver to shut checkstops).
2. Remove four Cover Screws M20-2C (CP) to release entire thermostatic control assembly. (M20-1-12B)

WHEN RE-ASSEMBLING VALVE, insert Cover Gasket M20-3C in base. Lubricate M20-6B O'Rings before re-inserting assembly.

After installing new parts, it will probably be necessary to reset high temperature limit. See instructions "TO RESET ADJUSTABLE HIGH TEMPERATURE LIMIT STOP" (page 2).

TO REMOVE BRIDGE ASSEMBLY (DWG. 2)

Remove MU-10B Pointer Rod Nut, remove M20-1-8B Bridge Assembly from pointer rod.

Improper blending of the water may be caused by a sticking condition in the M20-G1 Port Sleeve Assembly. The Thimble should slide freely on the Port Sleeve.

Clean with a NON-CORROSIVE CLEANING AGENT AND SOFT CLOTH. DO NOT USE ABRASIVES, then wash parts thoroughly.

To reassemble, replace Bridge Assembly on pointer rod. M20-14B Driving stud **MUST** engage in thimble and hole in coil bracket. Replace pointer rod nut.

DO NOT apply grease or lubricants to the M20-G1 Port Sleeve Assembly.

TO DISASSEMBLE BRIDGE ASSEMBLY (DWG. 3)

Remove M20-5B Holder Nuts using a screwdriver in the slots provided. Clean or replace M20-G1 Port Sleeve Assembly following instructions above. When reassembling, check M20-3B port sleeve packings and replace if necessary.

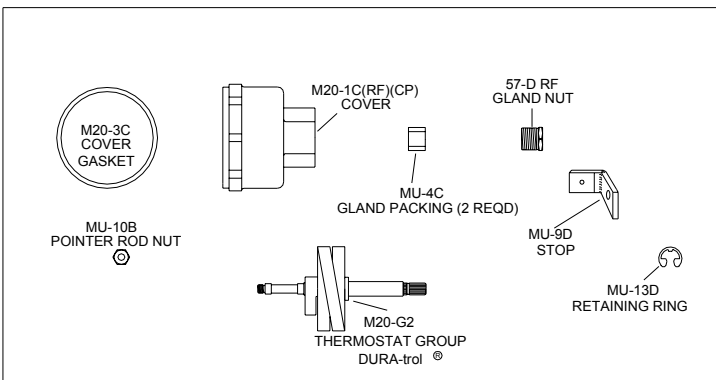

TO CLEAN OR REPLACE THERMOSTAT GROUP

Remove stop retaining ring and stop. Loosen gland nut. Push rod through cover. BE CAREFUL NOT TO PULL THERMOSTAT COIL OUT OF SHAPE.

To clean, if a deposit has collected on the thermostat group, brush in a non-corrosive cleaning solution. Rinse in clean water and replace in cover with parts as shown.

NOTE: AFTER INSTALLING NEW PARTS IT WILL BE NECESSARY TO RESET THE ADJUSTABLE HIGH TEMPERATURE LIMIT STOP (SEE PAGE 2).

REMEMBER: THIS IS A CONTROL DEVICE WHICH MUST BE CLEANED ON A REGULAR BASIS (SEE MAINTENANCE GUIDE AND RECORD, MGR-1000).

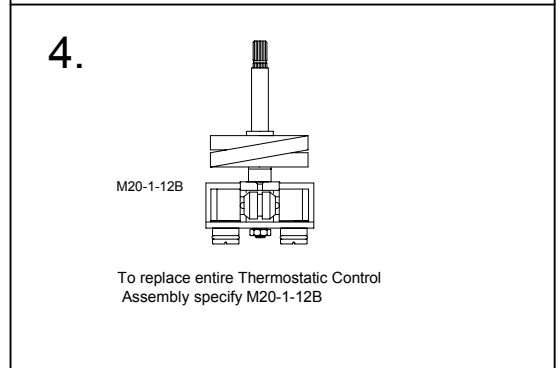
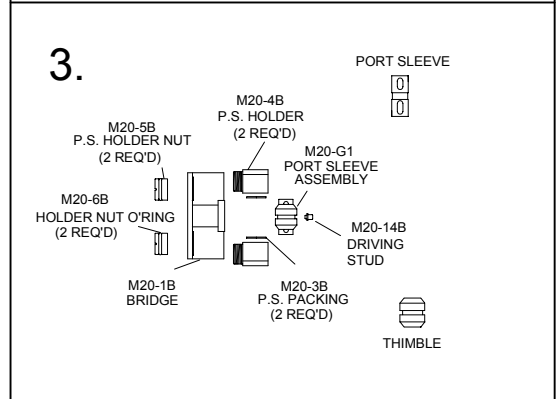
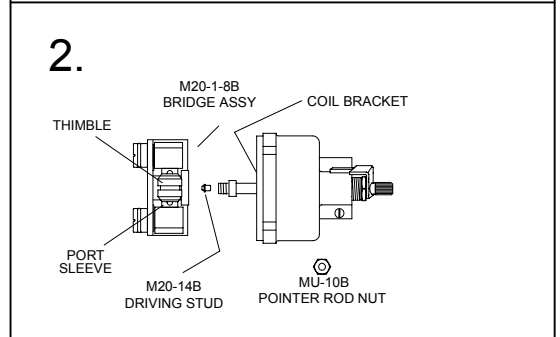
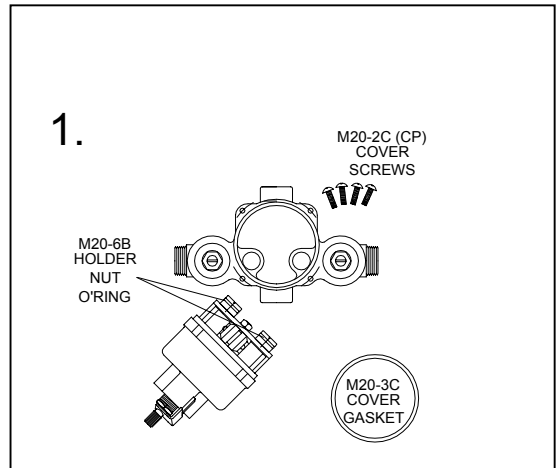

TM-15/20 VALVE PARTS

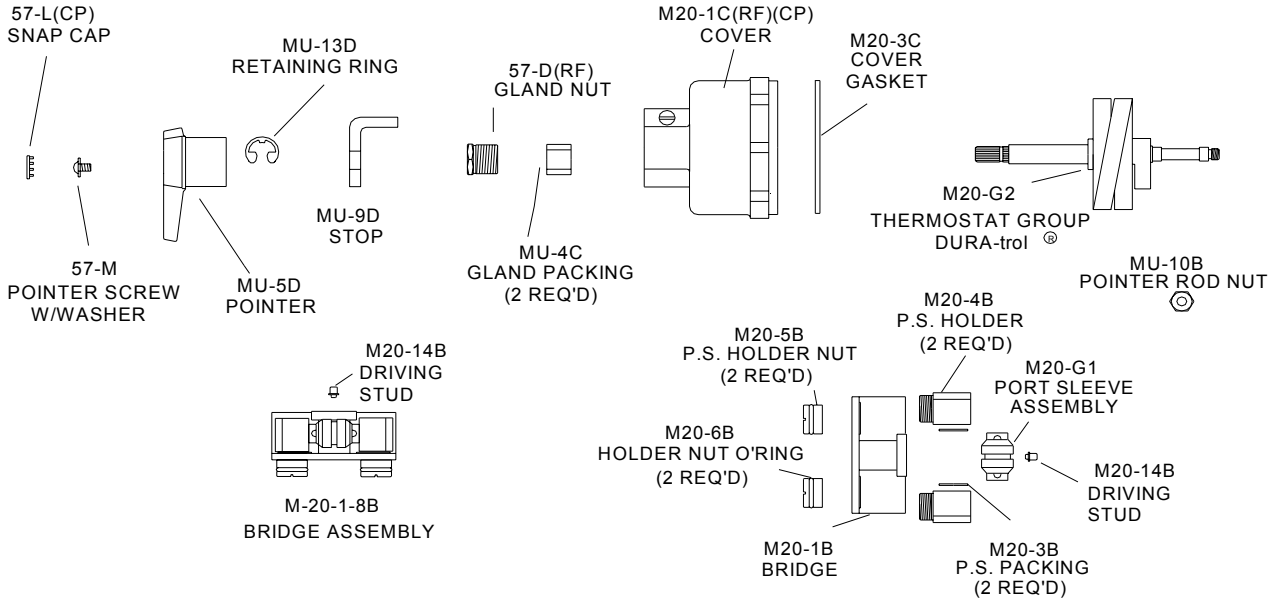

CHECKSTOP PARTS

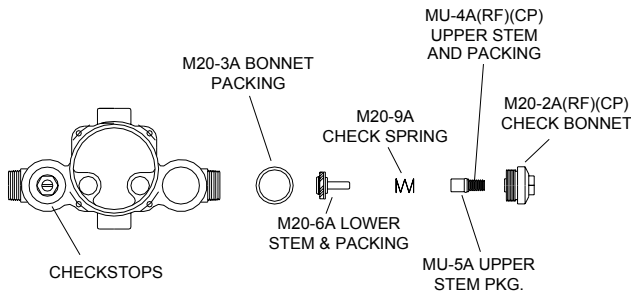

LOCK-TYPE POINTER (SUFFIX LTR)

Some TM valves are furnished with lockable Pointers. See part noted

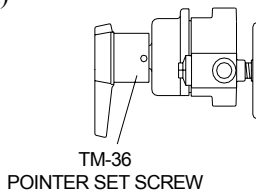

REMEMBER! THIS IS A CONTROL DEVICE WHICH MUST BE CLEANED AND MAINTAINED ON A REGULAR BASIS (SEE MAINTENANCE GUIDE AND RECORD, MGR-1000).

NOTE: AFTER INSTALLING NEW PARTS IT WILL BE NECESSARY TO RESET THE ADJUSTABLE HIGH TEMPERATURE LIMIT STOP ON EACH VALVE (SEE PAGE 2).

GROUP

Push rod through cover. Be careful not to pull coil out of shape. If a deposit has collected on the thermostat group (M20-G2) brush in a non-corrosive cleaning solution.

REPAIR KITS

REPAIR KIT 1/M20 PACKINGS & GASKETS

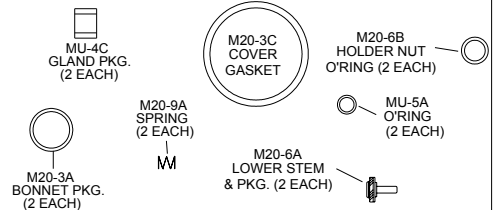

REPAIR KIT R/M20 REBUILDING KIT

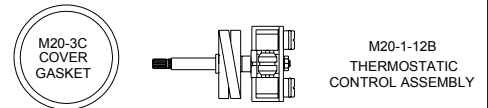

REPAIR KIT 4/M20 REBUILDING KIT

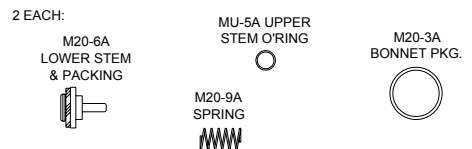

FLOW CAPACITIES

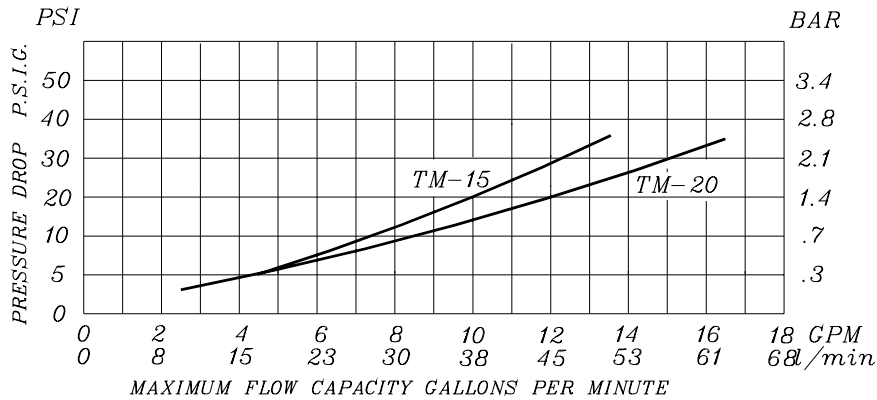

CAUTION! All thermostatic water mixing valves have limitations. They will not provide the desired accuracy outside of their flow capacity range. Consult the capacity chart and **DO NOT OVERSIZE**. Minimum flow must be no less than shown below.

MODEL	IN	OUT	MINIMUM FLOW (GPM) (l/min)	SYSTEM PRESSURE DROP (PSIG)										PSI BAR
				5 .3	10 .7	15 .97	20 1.4	25 1.7	30 2.1	35 2.4	40 2.8	45 3.1	50 3.4	
TM-15-E	1/2"	3/4"	1.0 3.7	4.5 17	7 26	8 30	10 38	12 45	13 49	14 53	15 57	16 60	17 64	GPM l/min
TM-20-E	3/4"	3/4"	1.0 3.7	5 19	7.3 28	9 34	11 42	13 49	14 53	15 57	16 60	17 64	18 68	GPM l/min

REMEMBER! THIS IS A CONTROL DEVICE WHICH MUST BE CLEANED AND MAINTAINED ON A REGULAR BASIS. (SEE MAINTENANCE GUIDE AND RECORD MGR-1000)

LIMITED WARRANTY

Leonard Valve Company warrants the original purchaser that products manufactured by them (not by others) will be free from defects in materials and workmanship under normal conditions of use, when properly installed and maintained in accordance with Leonard Valve Company's instructions, for a period of one year from date of shipment. During this period the Leonard Valve Company will at its option repair or replace any product, or part thereof, which shall be returned, freight prepaid, to the Leonard factory and determined by Leonard to be defective in materials or workmanship. There are no warranties, express or implied, which extend beyond the description contained herein. There are no implied warranties of merchantability or of fitness for a particular purpose. In no event will Leonard be liable for labor or incidental or consequential damages. Any alteration or improper installation or use of the product will void this limited warranty.

1360 Elmwood Avenue, Cranston, RI 02910 USA

Phone: 401.461.1200 Fax: 401.941.5310

Email: info@leonardvalve.com

Web Site: <http://www.leonardvalve.com>