

PNV-200-LF-3PS

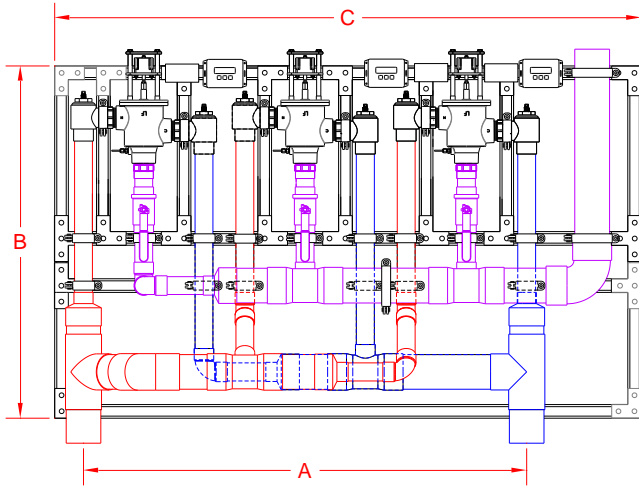

$A = 53'' \pm 4''$ $B = 42'' \pm 4''$
 $C = 70'' \pm 4''$

NOTE: Options may change dimensions

STANDARD CONTROL BOX



NEW "ENHANCED FEATURE SET" CONTROL BOX SEE SELECTABLE OPTIONS PAGE 2



This product meets Low Lead requirements of wetted surface area containing less than 0.25% lead by weight



WARNING: This product can expose you to chemicals including lead, which is known to the State of California to cause cancer. For more information, go to www.P65Warnings.Ca.gov

- Three Digital Mixing Valves with check stops, integral RTD Sensors
- 4" inlets, 4" outlet (76mm X 102mm)
- 0.25 GPM** (.95 L/min) minimum flow capacity each
- Maximum operating pressure: 125 PSIG (860 KPA)
- Controls water temperature to $\pm 2^\circ\text{F}$ in accordance with ASSE 1017
- Controls water temperature to $\pm 2^\circ\text{F}$ during times of low / no system demand
- Automatic Hot/Cold Water shutoff upon cold/ hot water inlet supply failure
- User programmable set point range between 65°F and 180°F
- UL Listed Control Box
- UL Listed 120V plug in power supply with 6' cord
- Simple/intuitive user commissioning and setup
- Factory assembled and tested

This product meets Low Lead requirements of wetted surface area containing less than 0.25% lead by weight

**NOTE: Each valve will maintain temperature with 0.25 GPM flow from the domestic hot water loop when properly installed near the hot water source with a continuously operating recirculation pump.

OPTIONS:

- ___ IOT – Internet of Things, Modbus to Wi-Fi gateway that connects to the Cloud to allow online monitoring of outlet temperature and Modbus connectivity to BMS
- ___ BPS – Back-up Power Supply, uninterruptable power supply with up to 2 hours run time in case of primary power loss

Valves are Pending ASSE 1017 Certified



Valves are Pending CSA Certified



Valve electronics are UL Certified



Product is non-cancellable and non-returnable from date of order with factory. Signed submittal required with purchase order.



1360 Elmwood Avenue, Cranston, RI 02910 USA

Phone: 401.461.1200 Fax: 401.941.5310

Email: info@leonardvalve.com

Web Site: <http://www.leonardvalve.com>

PNV-CONTROLLER OPTIONS

Standard Controller 1.0 Version



A = 6" B = 4"
Depth = 1-3/4"

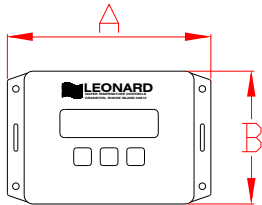

Enhanced Controller 2.0, 2.5, 3.0 Versions



A = 8" B = 4-3/4"
Depth = 1-1/4"

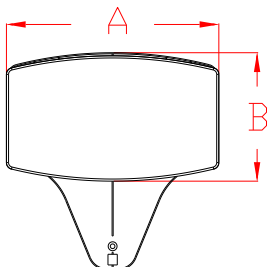

Leonard Valve Company reserves the right of product, or design modifications without notice or obligation.

STANDARD CONTROLLER:

_____ **1.0** – See PAGE 1 for info

ENHANCED CONTROLLER OPTIONS:

UL Listing Pending on 2.0, 2.5 and 3.0 controllers
Note: Boxes not field upgradeable

_____ **2.0** – Enhanced Proton Controller with Programmable Disinfection Mode

Options:

- _____ **REL** – 5 Relay Contacts that Switch during Alarm State
- Helpful for Remote Alerts Within Building to Assist Maintenance and Service Personnel
 - 5 Unique States:
 - Loss of Power
 - Broken Temperature Probe
 - “Out of Range” Temperature ($\pm 10^{\circ}\text{F}$)
 - Motor Connectivity and Operation
 - Maintenance (Service Required) @ $< 90\%$ Full travel

_____ **2.5** – Enhanced Proton Controller including all of 2.0 as well as BACnet MS/TP Connection which provides ability to serve up all data to BMS system

Options:

- _____ **3T** – Three Additional Temperature Sensors for Monitoring of Inlet Hot, Inlet Cold, and Return Temperatures
- _____ **REL** – 5 Relay Contacts that Switch during Alarm State (as shown above)

_____ **3.0** – Enhanced Proton Controller including all of 2.5 as well as all items below as standard,

- WiFi – Wifi enabled
- 3T - 3 Additional Temperature Sensors for Monitoring of Inlet Hot, Inlet Cold and Return Temperatures
- REL - 5 Relay Contacts that Switch during Alarm State

**AVAILABLE \approx 2nd Quarter 2023



1360 Elmwood Avenue, Cranston, RI 02910 USA
Phone: 401.461.1200 Fax: 401.941.5310
Email: info@leonardvalve.com
Web Site: <http://www.leonardvalve.com>

Single Valve Flow Capacity shown, Triple flow rate when all valves are running

MINIMUM FLOW (GPM) (l/min)	PRESSURE DROP										
	5	10	15	20	25	30	35	40	45	50	PSI
	.3	.7	.97	1.4	1.7	2.1	2.4	2.8	3.1	3.4	BAR
0.25** (.95)	80	115	130	147	165	173	189	198	215	226	GPM
	303	435	492	556	625	655	715	750	814	856	l/min

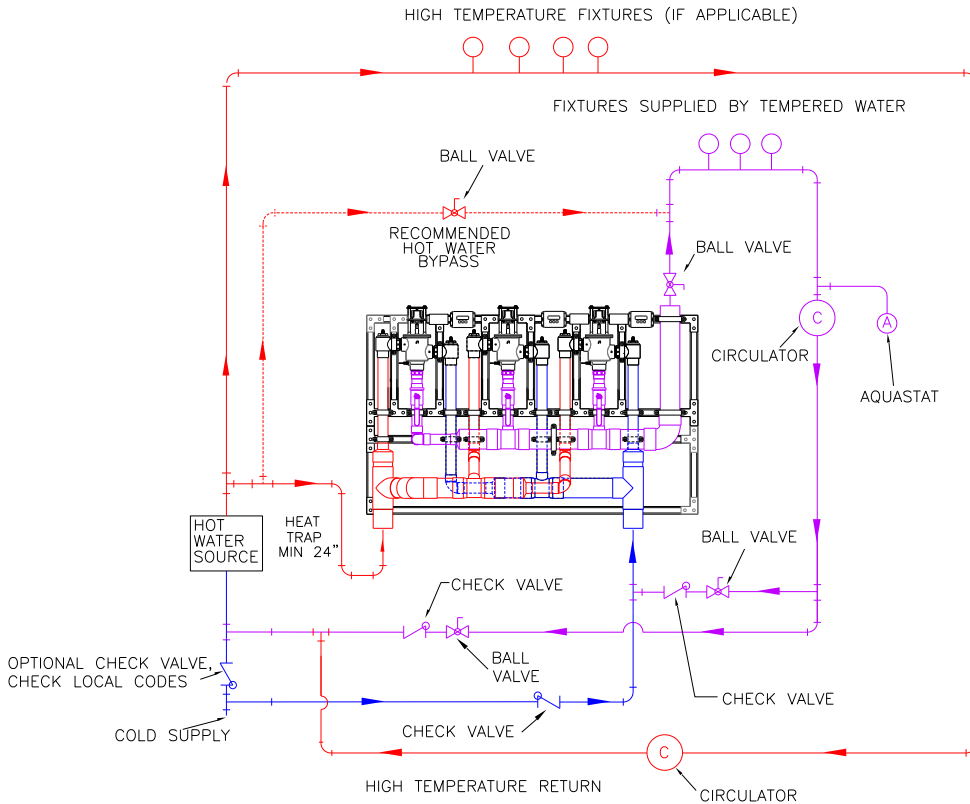

CAUTION! All thermostatic water mixing valves have limitations. They will NOT provide the desired accuracy outside of their flow capacity range. Consult the Flow Capacity Chart and DO NOT OVERSIZE. Minimum flow must be no less than as indicated.

NOTE: Flow rates will vary depending on existing field conditions. Leonard Valve Company always recommends using CASPAK® sizing software for proper valve sizing and model number applications.

Engineer's Approval

Job # _____

Arch/Eng. _____

Contractor _____

Note: The models shown represent Leonard Products which are believed to be equivalent in type and function to items specified. Leonard Valve Company is not responsible for errors or omissions due to differences in interpretations of information provided.

Note: Leonard Valve Company reserves the right of product, or design modifications without notice or obligation.



1360 Elmwood Avenue, Cranston, RI 02910 USA

Phone: 401.461.1200 Fax: 401.941.5310

Email: info@leonardvalve.com

Web Site: <http://www.leonardvalve.com>