

HIGH LOW MANIFOLD SYSTEM

ECO-MIX™

TM-1520B-2PS-LF PARALLEL INSTALLATION WITH STRUT

- Large Type TM Thermostatic water mixing valve, adjustable high temperature limit stop*, inlet checkstops, wall support, outlet ball valve
- Small Type TM Thermostatic water mixing valve, adjustable high temperature limit stop*, inlet checkstops, outlet ball valve
- Maximum operating pressure: 125 PSI (860 KPA)
- 2" inlets, 2" outlet (51mm X 51mm)
- 2 GPM (8 l/min) minimum flow capacity
- Inlet/Outlet manifold piping
- Dial thermometer on outlet
- Mounted on galvanized strut
- Locking temperature regulators
- Factory assembled and tested

Valve assemblies are ASSE 1017 Certified



Valve assemblies are CSA Certified



OPTIONS

- ___ SUFFIX TC- Test connection
- ___ SUFFIX IT- Inlet thermometers
- ___ IBV150-2PS -Inlet ball valves on all hot & cold inlets

Note: Leonard Valve Company reserves the right of product, or design modifications without notice or obligation.



WARNING: This product can expose you to chemicals including lead, which is known to the State of California to cause cancer. For more information, go to www.P65Warnings.Ca.gov

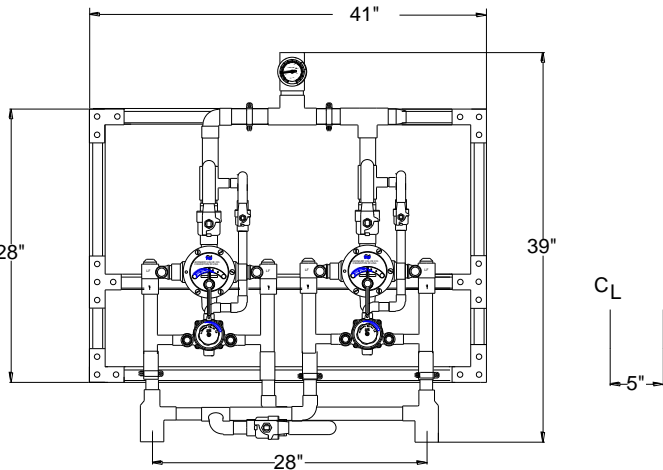

See page #2 for piping diagram

+NOTE: The valve will maintain temperature with 0.5GPM flow from the domestic hot water loop when properly installed near the hot water source with a continuously operating recirculation pump.

Valve assemblies are certified to meet Low-Lead requirements of wetted surface area containing less than 0.25% lead by weight. All other fittings and components, the sum total of which comprise the wetted surface of this product contain less than one quarter of one percent of lead by weight.

Product is non-cancellable and non-returnable from date from order with factory. Signed submittal required with purchase order.

NOTE: Flowrates will vary depending on existing field conditions. Leonard Valve Company always recommends using CASPAK® sizing software for proper valve sizing and model number applications.

CAUTION! All thermostatic water mixing valves have limitations. They will NOT provide the desired accuracy outside of their flow capacity range. Consult the Flow Capacity Chart and DO NOT OVERSIZE. Minimum flow must be no less than as indicated.

***NOTE:** A limit stop, set for 120°F (49°C), is simply a mechanical setting to prevent excessive handle rotation. If incoming water is hotter than 150°F (65.5°C), the temperature of the factory test, the valve when turned to full HOT may deliver water in excess of 120°F and the limit stop MUST BE RESET BY THE INSTALLER

Job # _____

Arch/Eng. _____

Contractor _____

Engineer's Approval

Note: The models shown represent Leonard Products which are believed to be equivalent in type and function to items specified. Leonard Valve Company is not responsible for errors or omissions due to differences in interpretations of information provided.



1360 Elmwood Avenue, Cranston, RI 02910 USA

Phone: 401.461.1200 Fax: 401.941.5310

Email: info@leonardvalve.com

Web Site: <http://www.leonardvalve.com>

TM-1520B-2P-LF-TC OPTION

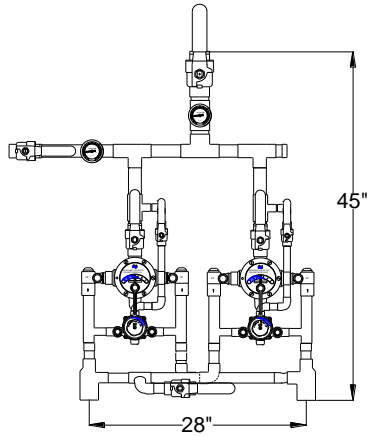

DOUBLE FLOWRATE WHEN BOTH VALVES ARE OPERATING SINGLE VALVE ASSEMBLY FLOWRATES SHOWN

| MINIMUM FLOW (GPM) (l/min) | SYSTEM PRESSURE DROP (PSIG) | | | | | | | | | | |
|-------------------------------|-----------------------------|-----|-----|-----|-----|-----|-----|-----|-----|-----|-------|
| | 5 | 10 | 15 | 20 | 25 | 30 | 35 | 40 | 45 | 50 | PSI |
| | .3 | .7 | .97 | 1.4 | 1.7 | 2.1 | 2.4 | 2.8 | 3.1 | 3.4 | BAR |
| 2.0 | 48 | 65 | 80 | 95 | 112 | 120 | 130 | 140 | 158 | 165 | GPM |
| 8 | 182 | 273 | 333 | 360 | 424 | 454 | 492 | 530 | 598 | 625 | l/min |

REQUIRED PIPING METHOD #5

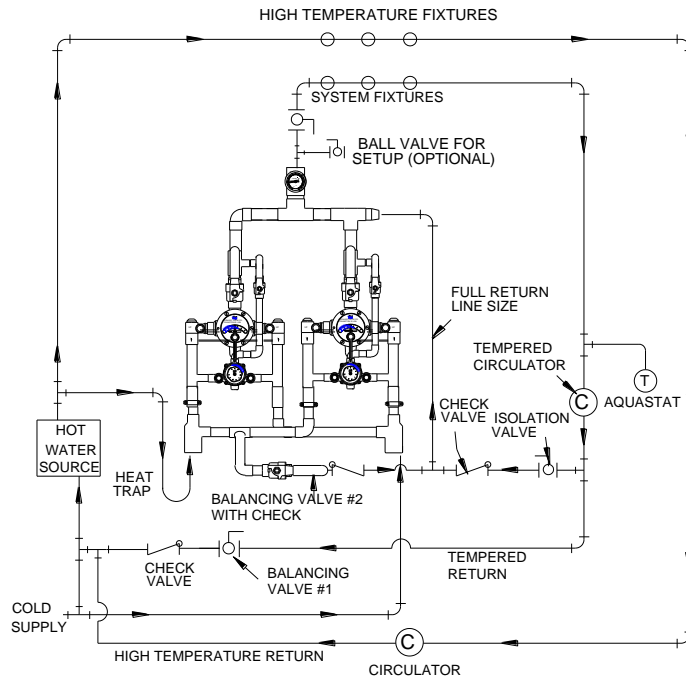

1360 Elmwood Avenue, Cranston, RI 02910 USA

Phone: 401.461.1200 Fax: 401.941.5310

Email: info@leonardvalve.com

Web Site: <http://www.leonardvalve.com>