

LVC THERMOSTATIC Showermaster® INSTALLATION INSTRUCTIONS

Serial No.46370 thru 54008

1. Valve must **NOT** be sealed in wall with plaster or tile. Cover screws and inlet fittings **MUST** be accessible for servicing.
2. It is recommended that the valve is furnished with inlet stops or checkstops on each supply.
3. Install hot to left inlet and cold to right inlet (see H and C marks on valve body).
4. Pipe cement, or solder flux must be used sparingly. After connections are made to the valve, flush pipes thoroughly (remove internal parts if necessary) to eliminate dirt and excess materials which might become lodged on the working parts of the valve.
5. On concealed models, attach protective cover, which serves as a guide for the finish wall line after piping connections are made.

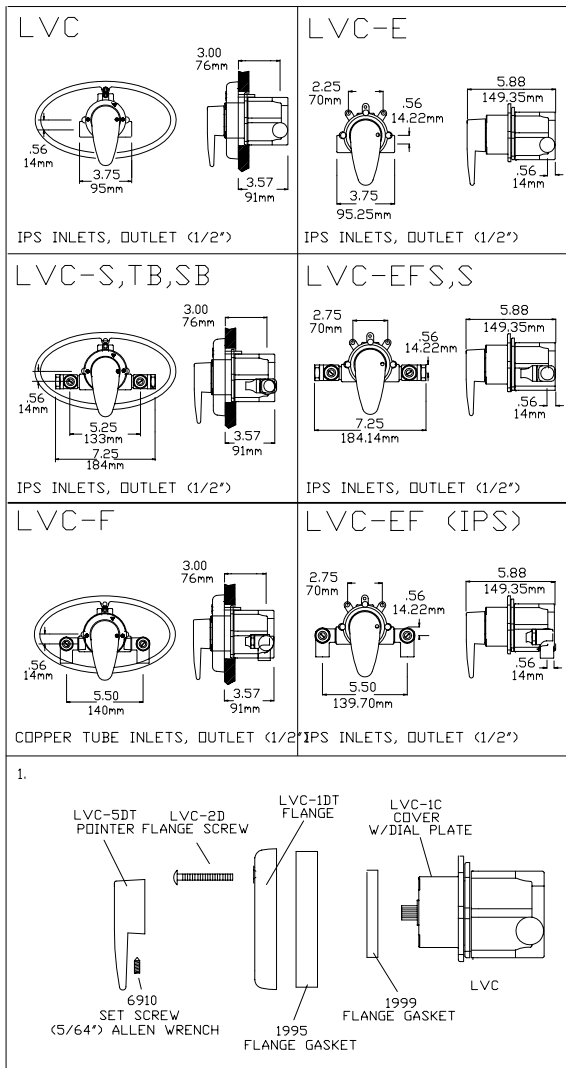

WARNING! HOT WATER OVER 110°F (43°C) IS DANGEROUS AND MAY CAUSE SCALDING!

WARNING

WARNING! THIS MIXING VALVE IS EQUIPPED WITH AN ADJUSTABLE HIGH TEMPERATURE LIMIT STOP FACTORY SET AT APPROXIMATELY 110°F (43°C) WITH AN INCOMING HOT WATER SUPPLY TEMPERATURE OF 135°F (57°C) IF INCOMING HOT WATER ON THE JOB IS HIGHER THAN 135°F (57°C), THE VALVE WHEN TURNED TO FULL HOT MAY DELIVER WATER IN EXCESS OF 110°F (43°C), AND THE HIGH TEMPERATURE LIMIT STOP **MUST BE RESET BY THE INSTALLER** (SEE PAGE 2)

6. **IMPORTANT!** The concealed LVC* valve is designed for top and bottom outlet. When used for showers, the top outlet only is used and the pipe plug is left in the bottom outlet. When used for shower AND tub, remove the pipe plug from the bottom outlet and pipe down to a diverter tub spout. No special elbow is required, (see installation drawings, page 4).* Exposed Models (LVC-E) are designed for top inlet only.
7. After the valve is installed as noted above, recheck and reset the adjustable high temperature limit stop (see instructions, page 2)
8. Mount the wall flange to the valve body, using the LVC-2D wall flange screw.
9. Attach the pointer to the valve stem (using the set screw (6910).

WALL
OPENING
TEMPLATE

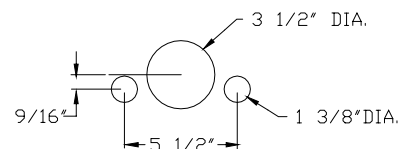

REMEMBER!! THIS IS A CONTROL DEVICE WHICH MUST BE CLEANED AND MAINTAINED ON A REGULAR BASIS (SEE MAINTENANCE GUIDE AND RECORD MGR-1000).

1360 Elmwood Avenue, Cranston, RI 02910 USA

Phone: 401.461.1200 Fax: 401.941.5310

Email: info@leonardvalve.com

Web Site: <http://www.leonardvalve.com>

OPERATION

The LVC is a thermostatic water mixing valve which will compensate for changes in the temperature or pressure of hot and cold supplies and maintain bathing temperatures. The easy to read dial with directional indicators helps to eliminate confusion as to where the handle should be located for a particular temperature. Turn the handle counter-clockwise from the "OFF" position through the **BLUE ARROW** (COLD) area on the dial plate, the shower is on and temperature is cold. As the handle is turned toward the **RED DOT** (HOT) area, shower temperature becomes progressively **WARMER** until the high temperature limit is reached in the full "HOT" position. (the **BLACK** dot on the pointer lines up with the **RED** dot on the cover) To turn OFF move handle back in clockwise direction to the "OFF" position (the **BLACK** dot on the pointer lines up with the **BLACK** dot on the cover).

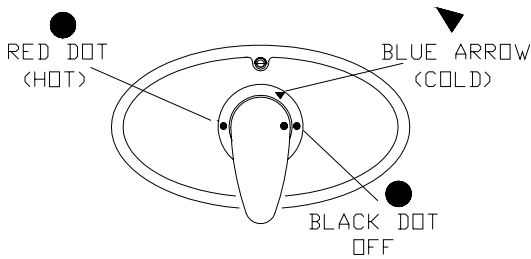

SERVICING INSTRUCTIONS

1. Remove pointer (LVC-SDT) by removing #6910 set screw (5/64" allen wrench). Remove wall flange screw (LVC-2D) and wall flange (LVC-1DT). (DWGS 1 & 2)
2. Turn off hot and cold supplies to the valve (using the inlet stops or checkstops if furnished).
3. Remove the four cover screws (MU-2C) and release the cover and thermostatic control assembly (DWG. 4). Do not misplace the cover gasket (LVC-3C). **DO NOT LOOSEN FACTORY SET TENSION NUT. (DWG. 6)**
4. To clean, submerge the assembly in clear water warm water to remove deposit or stain. Use a mild solution of household ammonia or non-corrosive cleaning solution to remove stubborn deposits. Replace the pointer on the valve stem and move to the left to make certain the inlet valve cups open and close vertically and that the thimble moves freely on the port sleeve (DWG. 5).
5. If the port sleeve assembly requires further cleaning, remove the control rod nuts (LVC-10B) and valve cups (LVC-25C), to release the bridge assembly (LVC-1-8B) and clean as noted above. The bridge assembly may be further disassembled by removing the two holder nuts (LVC-5B) to clean the port sleeve assembly.
6. When cleaning the port sleeve assembly, **DO NOT USE ABRASIVES. DO NOT LUBRICATE THE PORT SLEEVE ASSEMBLY** as it will limit the performance of the valve.
7. Place cover gasket in recess, return complete assembly to valve base and tighten cover screws, **NOTE TEMPERATURE LIMIT STOP MUST BE RESET AFTER REASSEMBLY!**

WARNING

WARNING! THIS MIXING VALVE IS EQUIPPED WITH AN ADJUSTABLE HIGH TEMPERATURE LIMIT STOP FACTORY SET AT APPROXIMATELY 110°F(43°C) WITH AN INCOMING HOT WATER SUPPLY TEMPERATURE OF 135°F(57°C). IF INCOMING HOT WATER ON THE JOB IS HIGHER THAN 135°F, THE VALVE WHEN TURNED TO THE FULL HOT MAY DELIVER WATER IN EXCESS OF 110°F, AND THE HIGH TEMPERATURE LIMIT STOP MUST BE RESET BY THE INSTALLER. (SEE BELOW)

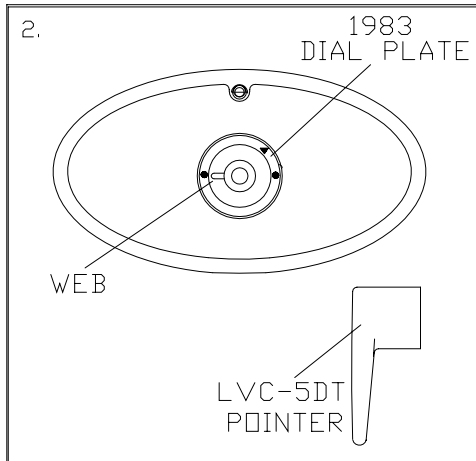

REMEMBER!! THIS IS A CONTROL DEVICE WHICH MUST BE CLEANED AND MAINTAINED ON A REGULAR BASIS (SEE MAINTENANCE GUIDE AND RECORD MGR-1000).

TO RESET HIGH TEMPERATURE LIMIT STOP (DWG. 3):

1. Turn pointer to the left or right until valve is delivering the highest desired temperature of 110°F (43°C) or lower.
2. Remove pointer from spline.
3. Replace pointer on the spline with the STOP, which is cast on the underside of the pointer, resting against the TOP side of the WEB which is cast on the cover.
4. If properly adjusted, the pointer should now move fully from the HOT position, where the **BLACK** dot on the pointer lines up with the **RED** dot on the cover, clockwise to the OFF position, where the **BLACK** dot on the pointer lines up with the **BLACK** dot on cover.

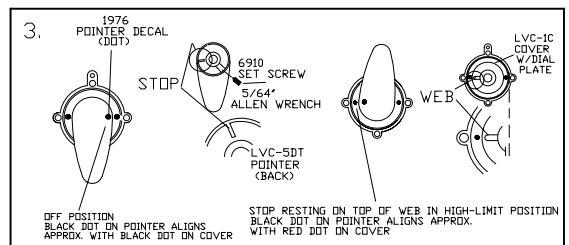

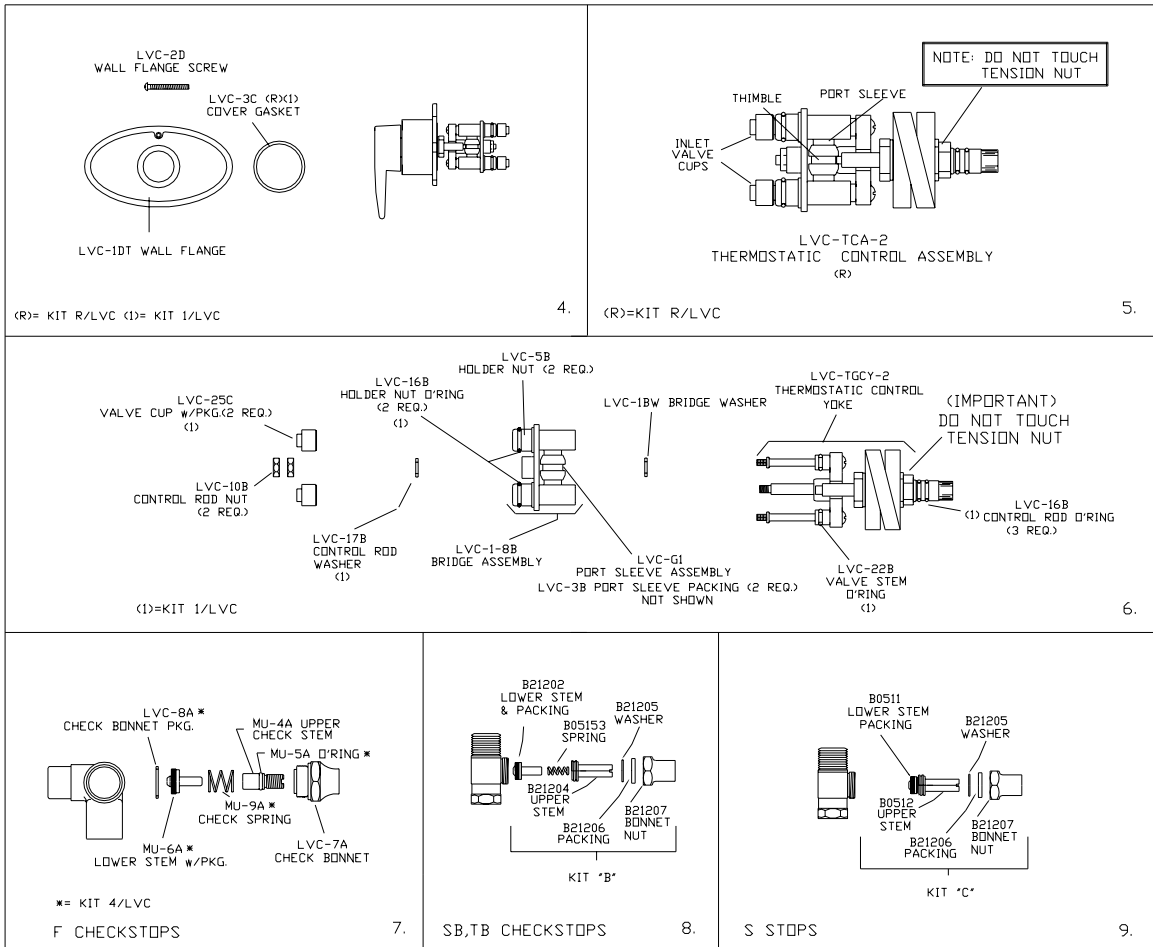

SERVICING INSTRUCTIONS

	SYMPTOM:	KIT REQUIRED:	PARTS INCLUDED:
PACKINGS & GASKETS	<ol style="list-style-type: none"> 1. Leak at handle. 2. Valve will not shut off completely. 3. Valve is difficult to pull apart. 	Kit 1/LVC (see DWG 6)	LVC-3C, 2 each LVC-22B, 27B, 25C, 3 each LVC-16B
PORT SLEEVE ASSEMBLY	<ol style="list-style-type: none"> 4. Valve delivers either all hot or all cold water, or will not mix consistently. 5. After packings and gaskets have been replaced, valve will not shut off completely. 	Replace parts noted (DWG.6) or KIT R/LVC	LVC-G1, LVC-3B (2 Req) or LVC-1-8B, plus packings noted. Or Kit R/LVC (LVC-TCA2, LVC-3C)
THERMOSTAT GROUP	<ol style="list-style-type: none"> 6. After replacing port sleeve assembly, valve will not hold temperature. 7. Valve does not respond when handle is turned (tension nut has been tampered with). 	Kit R/LVC (see DWG.5)	LVC-TCA-2, LVC-3C NOTE: DO NOT TOUCH TENSION NUT LOCATED BELOW LVC-16B O'RINGS
CHECKSTOPS, STOPS	<ol style="list-style-type: none"> 8. Supplies cannot be shut off completely. 9. Leak at checkstop (or stop) bonnet or stem. 	Kit 4/LVC KIT "B" KIT "C"	SEE DWG #7, 8, or 9 ABOVE FOR REPAIR KITS

INSTALLATION

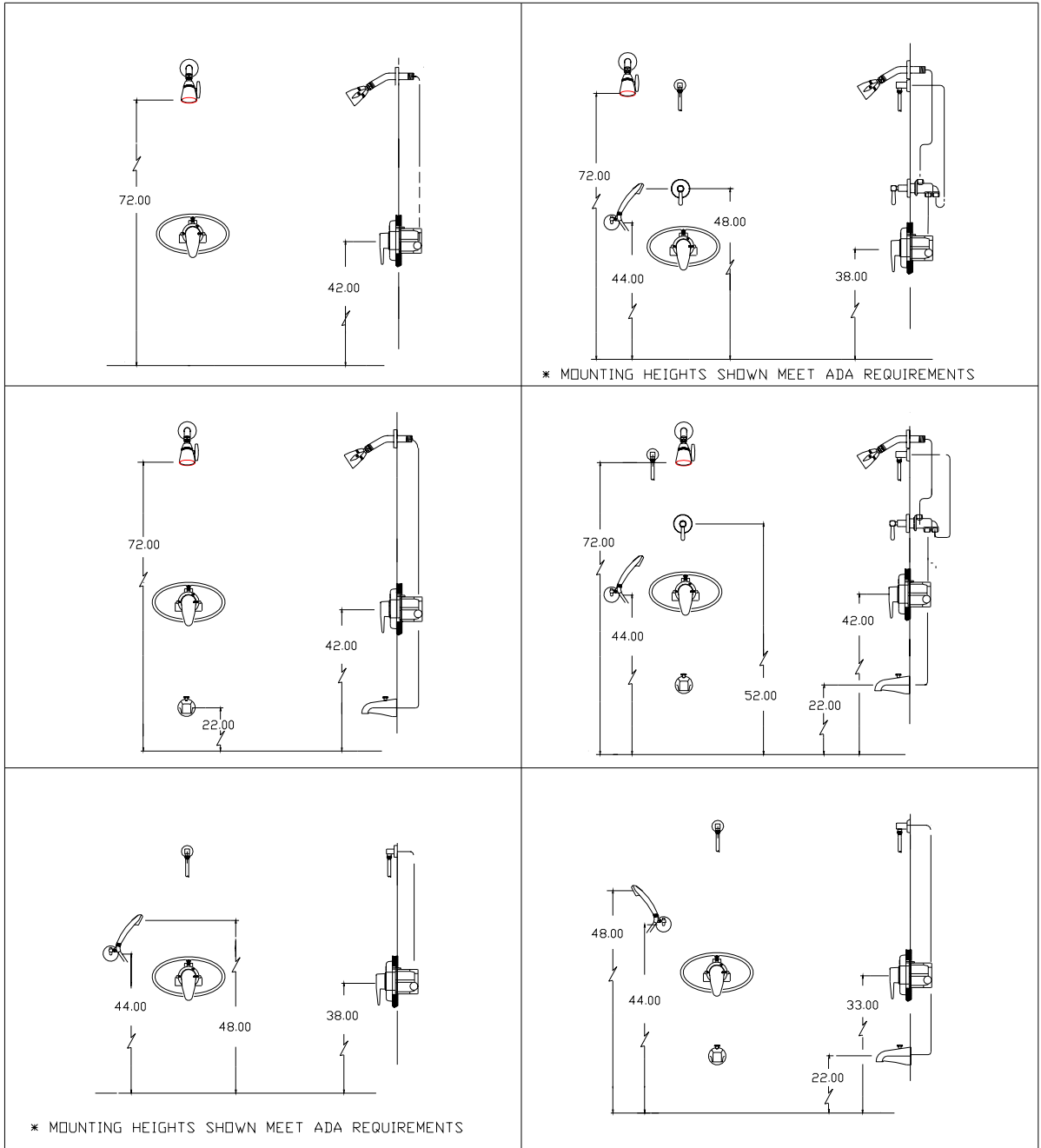

LIMITED WARRANTY

Leonard Valve Company warrants the original purchaser that products manufactured by them (not by others) will be free from defects in materials and workmanship under normal conditions of use, when properly installed and maintained in accordance with Leonard Valve Company's instructions, for a period of one year from date of shipment. During this period the Leonard Valve Company will at its option repair or replace any product, or part thereof, which shall be returned, freight prepaid, to the Leonard factory and determined by Leonard to be defective in materials or workmanship. There are no warranties, express or implied, which extend beyond the description contained herein. There are no implied warranties of merchantability or of fitness for a particular purpose. In no event will Leonard be liable for labor or incidental or consequential damages. Any alteration or improper installation or use of the product will void this limited warranty.

Printed in USA