

INSTALLATION ADJUSTMENT SERVICE HIGH-LOW MANIFOLD SYSTEMS

TM-420A, TM-420A-LF

IMPORTANT! Provide serial numbers for both valves when ordering parts!!
Top valve TM-26A manufactured after July 2007 starting with serial # TM260001A
Bottom valve TM-20 manufactured after July 2007 starting with serial # TM2039272

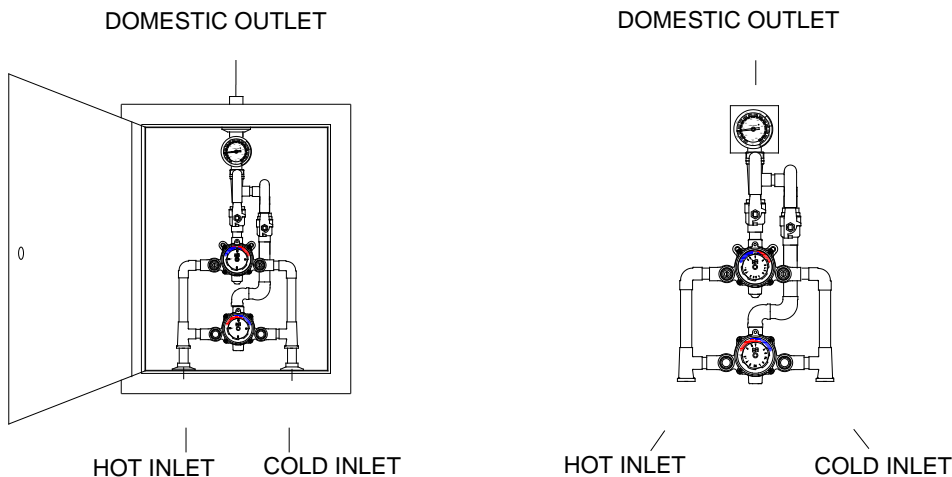

INSTALLATION

1. Type TM manifold systems are factory pre-assembled and tested and include large and small thermostatic water mixing valves which function as a system to meet both high and low demand for tempered water.
2. System should be installed at a location where it can easily be cleaned, adjusted or repaired.
3. System supplies must be connected as shown (Hot-left, Cold-right). Exercise caution when soldering.
4. Flush pipes thoroughly after system has been connected.
5. If this assembly is installed on a recirculated hot water system it **MUST** be piped according to **REQUIRED PIPING METHOD #2** (see page 4).
6. Refer to page 3 of this bulletin for correct Setup Instructions.

Maximum Operating Pressure 125PSI (860 KPA) for Hot and Cold Water.

CAUTION

All thermostatic water mixing valves have limitations. They will not provide the desired accuracy outside of their flow capacity range. Consult the capacity chart on page 8. Minimum flow must be no less than as shown.

REMEMBER! THIS IS A CONTROL SYSTEM WHICH MUST BE CLEANED AND MAINTAINED ON A REGULAR BASIS (SEE MAINTENANCE GUIDE AND RECORD MGR-1000).

1360 Elmwood Avenue, Cranston, RI 02910 USA

Phone: 401.461.1200 Fax: 401.941.5310

Email: info@leonardvalve.com

Web Site: <http://www.leonardvalve.com>

ADJUSTMENT AND SERVICE

Leonard Type TM Thermostatic Water Mixing Valves are simple in design and may be easily cleaned, adjusted and repaired. If the installation is accessible, servicing may be completed without disconnecting the valves.

NOTE: High Low Manifold Systems include Thermostatic Water Mixing Valves, which must be regularly maintained to provide best performance. Frequency of cleaning depends on quality of local water conditions and usage. See Maintenance Guide and Record MGR-1000.

WARNING

These mixing valves are equipped with an adjustable high temperature limit stop factory set at approximately 120°F (49°C) with an incoming hot water supply temperature of 150°F (65.5°C). If the hot water supply temperature of the job is greater than 150°F (65.5°C), the valves when turned to full HOT will deliver water in excess of 120°F (49°C) and the limit stops **MUST BE RESET BY THE INSTALLER!**

TO RESET ADJUSTABLE HIGH TEMPERATURE LIMIT STOP:

TM-26A (TOP VALVE)

TM-20 (BOTTOM VALVE)

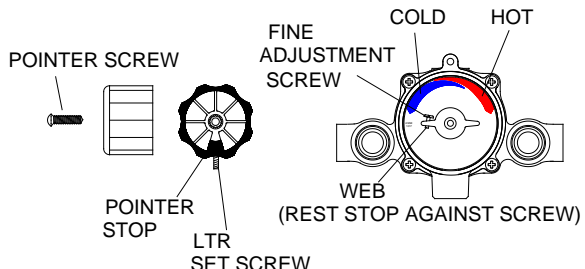
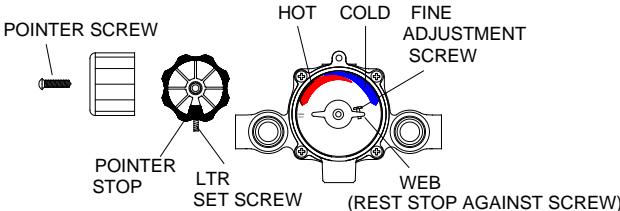
 <ol style="list-style-type: none">1. Loosen LTR Set Screw, remove POINTER SCREW.2. Adjust POINTER to maximum desired temperature.3. Remove POINTER, replace POINTER on spline rod with STOP (which is cast into the underside on the pointer), resting against the BOTTOM side of the WEB on the FINE ADJUSTMENT SCREW.4. If fine adjustment is needed, adjust FINE ADJUSTMENT SCREW on the cover, loosen for hotter or tighten for cooler temperature.5. Replace POINTER and check temperature, if set to desired temperature replace POINTER SCREW, and tighten LTR SET SCREW.6. The new maximum temperature has now been set. Test this temperature by holding a thermometer under the flow of water to be certain it is as desired. <p>* LIMIT STOP MUST BE RESET AND RECHECKED EACH TIME HANDLE IS REMOVED.</p>	 <ol style="list-style-type: none">1. Loosen LTR SET SCREW, remove POINTER SCREW.2. Adjust POINTER to maximum desired temperature.3. Remove POINTER, replace POINTER on spline rod with STOP (which is cast into the underside on the pointer), resting against the BOTTOM side of the WEB on the FINE ADJUSTMENT SCREW.4. If fine adjustment is needed, adjust FINE ADJUSTMENT SCREW on the cover, loosen for hotter or tighten for cooler temperature.5. Replace POINTER and check temperature, if set to desired temperature replace POINTER SCREW, and tighten LTR SET SCREW.6. The new maximum temperature has now been set. Test this temperature by holding a thermometer under the flow of water to be certain it is as desired. <p>* LIMIT STOP MUST BE RESET AND RECHECKED EACH TIME HANDLE IS REMOVED.</p>
--	--

**IMPORTANT! BOTH MIXING VALVES MUST BE SET AT THE SAME OPERATING TEMPERATURE.
SEE PAGES: 6 & 7 FOR COMPLETE PARTS BREAKDOWN**

Check for significant variations in outlet flow. Thermostatic valves will NOT provide the desired accuracy outside of their flow capacity range. Minimum flows must be no less than shown (see Flow Capacities, page 8).

If installed on a recirculated hot water system, make certain the valve is piped according to Leonard Required Piping Method #2 (see page 4).

REMEMBER! THIS IS A CONTROL DEVICE WHICH MUST BE CLEANED AND MAINTAINED ON A REGULAR BASIS. (SEE MAINTENANCE GUIDE AND RECORD, MGR-1000).

SETUP INSTRUCTIONS

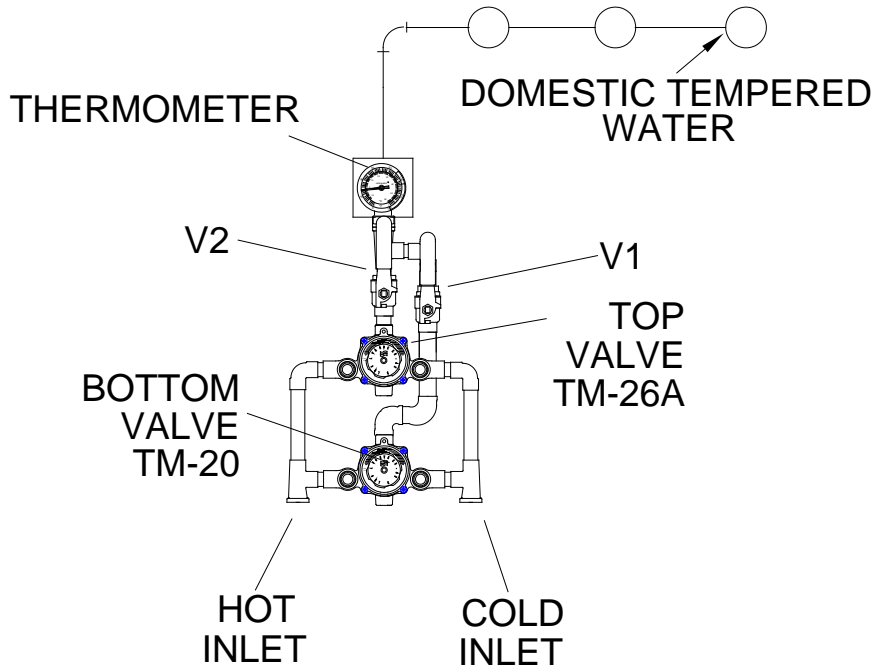

1. TM-186 High-Low Unit MUST be piped according to Method #2 (see page 4).
2. Make sure full hot and cold supplies to this assembly are operating. The temperature of the hot water source must be properly set and maintained
3. The circulator (if used) must be turned OFF before setup.
4. Turn on enough fixtures for a flow of at least 2 GPM downstream from this system. Make sure each fixture is set to deliver full "HOT" water.
5. Close outlet Valve V1 at the bottom Type TM Valve.
6. Make sure Valve V2 at the top Type TM Valve is in the full open position.
7. Set outlet temperature of the top Type TM Valve to the required level.
8. Open outlet Valve V1 at the bottom TM Valve.
9. Shut outlet Valve V2 at the top TM valve.
10. Turn on enough fixtures for a flow of at least 2 GPM downstream from this system. Make sure each fixture is set to deliver full "HOT" water.
11. Set outlet temperature of the bottom TM valve to the same temperature as the top TM Valve.
12. Open outlet Valve V2. System is operational.
13. IMPORTANT!! See page 4 to balance recirculation system.

* NOTE! FOR OPTIONAL OUTLET SETUP PIPING ARRANGEMENT, SEE PAGE 8

REQUIRED METHOD OF PIPING (RECIRCULATED DOMESTIC WATER SYSTEMS)

METHOD #2

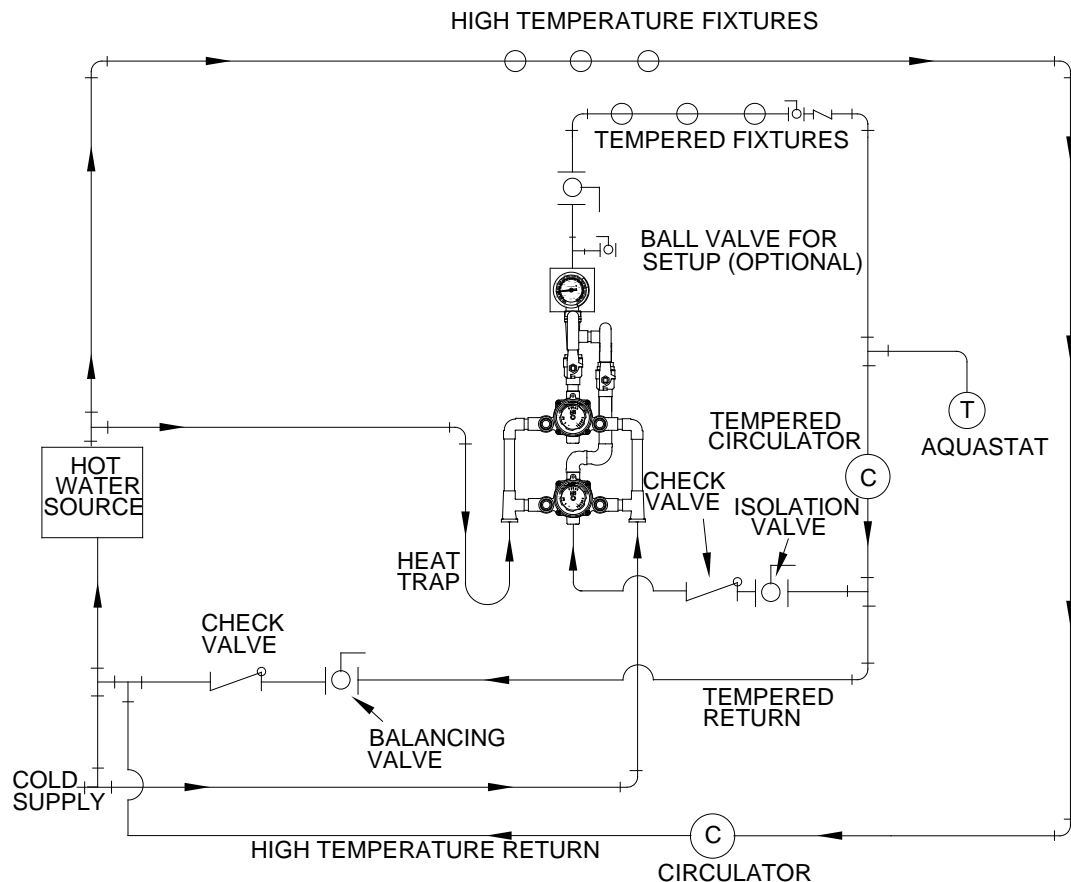

THIS PIPING METHOD IS NOT TO BE USED FOR MORE THAN ONE BUILDING

PROCEDURE TO BALANCE RECIRCULATION SYSTEM

1. MAKE SURE NO WATER IS BEING DRAWN IN THE BUILDING. OPEN BALANCING VALVE, APPROXIMATELY HALF WAY AND START CIRCULATOR.
2. OBSERVE TEMPERATURE UNTIL IT STABILIZES.
3. CLOSE BALANCING VALVE SLIGHTLY IF TEMPERATURE IS TOO HOT, OR OPEN IT SLIGHTLY IF TEMPERATURE IS TOO COLD AND ALLOW TEMPERATURE TO STABILIZE. REPEAT UNTIL DESIRED RECIRCULATED TEMPERATURE IS SET.

REMEMBER! THIS IS A CONTROL DEVICE WHICH MUST BE CLEANED AND MAINTAINED ON A REGULAR BASIS (SEE MAINTENANCE GUIDE AND RECORD, MGR-1000).

INSTRUCTIONS FOR SERVICING TOP TM-26 VALVE

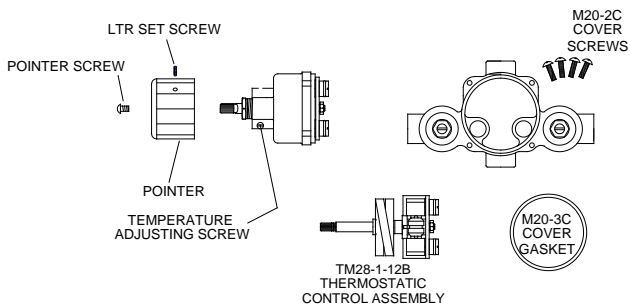

1. Loosen LTR set set screw.
2. Remove pointer screw, and pointer.
3. Turn off hot and cold supplies at screwdriver checkstops. Remove M20-2C cover screws to release cover and thermostatic control assembly.
4. To remove bridge assembly, TM28-1-8B, remove pointer rod nut (MU-10B) and pull bridge assembly off control rod.

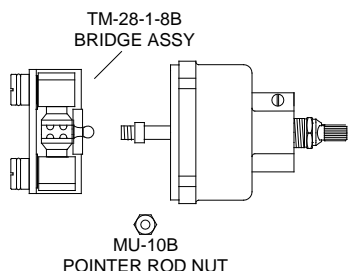

5. To clean, submerge bridge in clean water or non-corrosive cleaning solution. **DO NOT USE ABRASIVES!** Be certain thimble moves freely on port sleeve. Note! Driving ball must engage slot in coil bracket when reassembling.
6. To clean thermostat coil, remove retaining ring and stop, loosen gland nut. Push rod through cover. Be careful not to pull coil out of shape.
7. Clean with a non-corrosive cleaning solution. **DO NOT USE ABRASIVES!**

INSTRUCTIONS FOR SERVICING BOTTOM TM-20 VALVE

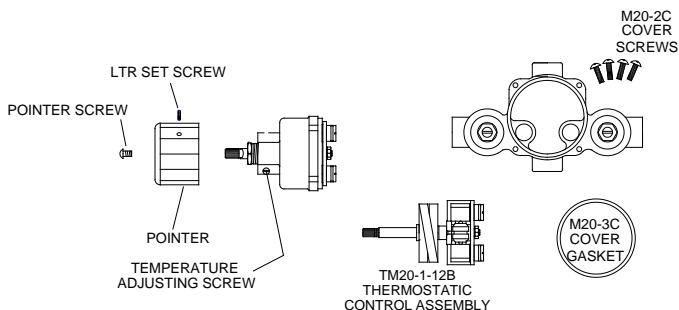

1. Loosen LTR set set screw.
2. Remove pointer screw, and pointer.
3. Turn off hot and cold supplies at screwdriver checkstops. Remove M20-2C cover screws to release cover and thermostatic control assembly.
4. To remove bridge assembly, M20-1-8B, remove pointer rod nut (MU-10B) and pull bridge assembly off control rod. Do not misplace M20-14B driving stud.

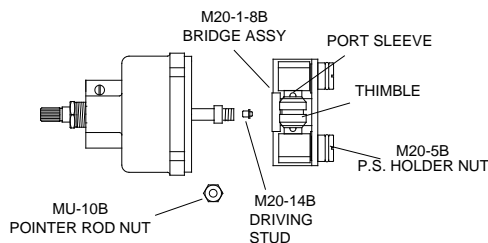

5. To clean, submerge bridge in clean water or non-corrosive cleaning solution. **DO NOT USE ABRASIVES!** Be certain thimble moves freely on port sleeve. Note! Driving stud (M20-14B) must engage slot in thimble when reassembling.
6. To clean thermostat coil, remove retaining ring and stop, loosen gland nut. Push rod through cover. Be careful not to pull coil out of shape.
7. Clean with a non-corrosive cleaning solution. **DO NOT USE ABRASIVES!**

TROUBLESHOOTING INSTRUCTIONS

Note: Provide valve serial number when ordering parts for either valve!

		LARGE VALVE TM-26A	SMALL VALVE TM-20
PACKING & GASKETS	<ol style="list-style-type: none"> 1. Leaks at stem. 2. Leak between valve cover and base. 	Repair Kit # 1/26Y	Repair Kit # 1/M20 (Packings & Gaskets)
PORT SLEEVE/BRIDGE ASSEMBLY	<ol style="list-style-type: none"> 3. Valve delivers either all hot or all cold water, or will not mix consistently. 	Repair Kit # R/28 (Rebuilding Kit) or TM28-1-8B Thermostat group	Repair Kit #R/M20 (Rebuilding Kit) or M20-1-8B Bridge Assembly
THERMOSTAT GROUP	<ol style="list-style-type: none"> 4. After cleaning or replacing port sleeve/ bridge assembly, valve performance is not consistent. 	Repair Kit # R/28 or TM-28-G2 Thermostat group	Repair Kit #R/M20 (Rebuilding Kit) or M-20-G2 Thermostat Group
CHECKSTOPS	<ol style="list-style-type: none"> 5. Hot water by-pass into cold line(or cold into hot). 6. Supplies cannot be shut off completely. Supplies leak at checkstop bonnets. 	Repair Kit #4/26Y (Checkstop Kit)	Repair Kit #4/M20 (Checkstop Kit)

See pages 6 & 7 for Parts Breakdowns

TM-26A VALVE PARTS

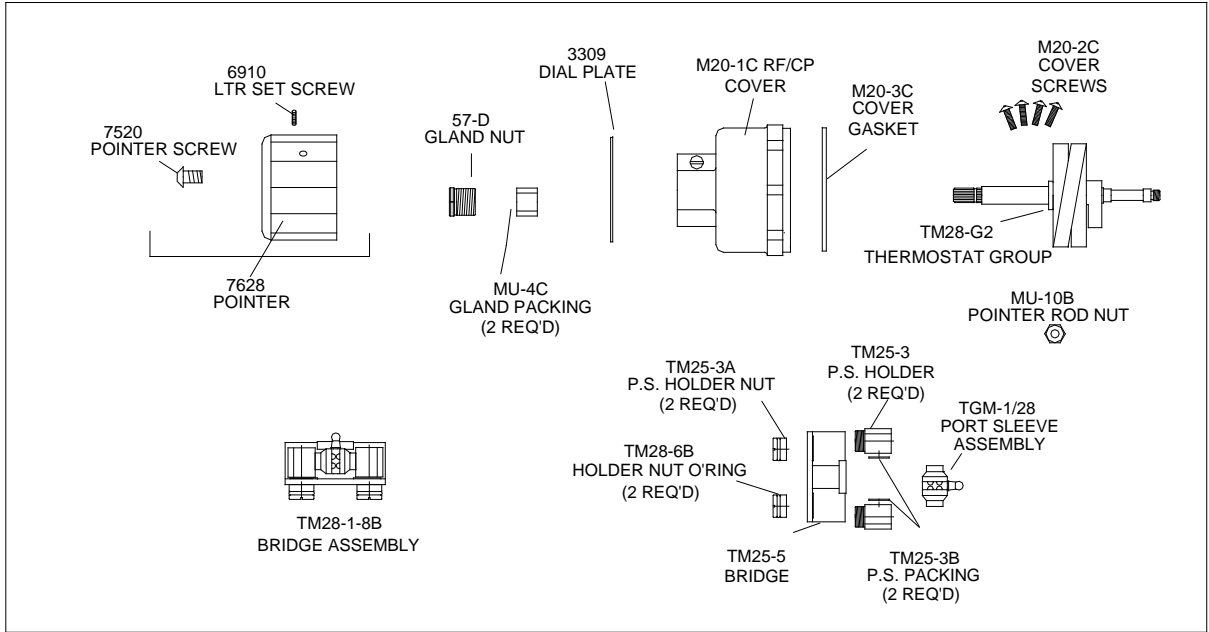

CHECKSTOP PARTS

REPAIR KITS

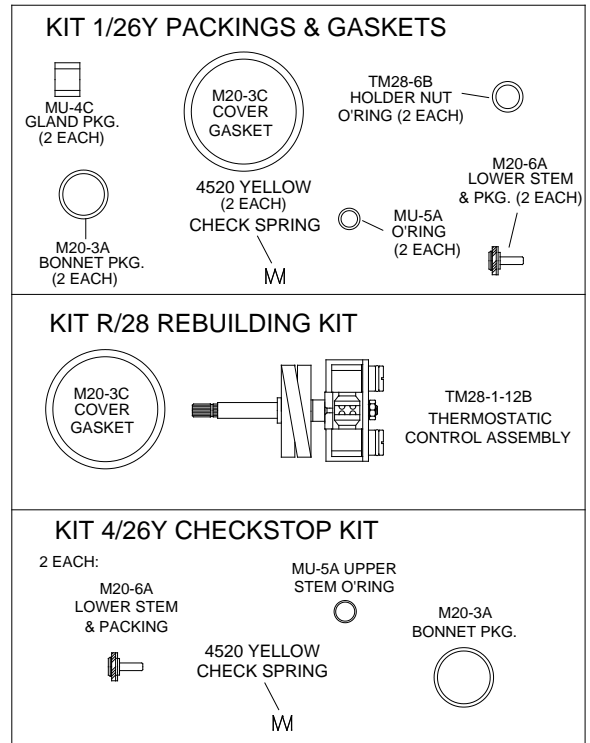
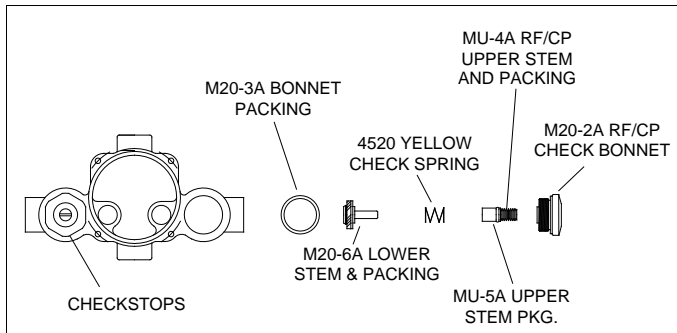

REMEMBER! THIS IS A CONTROL DEVICE WHICH MUST BE CLEANED AND MAINTAINED ON A REGULAR BASIS (SEE MAINTENANCE GUIDE AND RECORD).

NOTE: AFTER INSTALLING NEW PARTS IT WILL BE NECESSARY TO RESET THE ADJUSTABLE HIGH TEMPERATURE LIMIT STOP ON EACH VALVE (SEE PAGE 2).

TM-20 VALVE PARTS

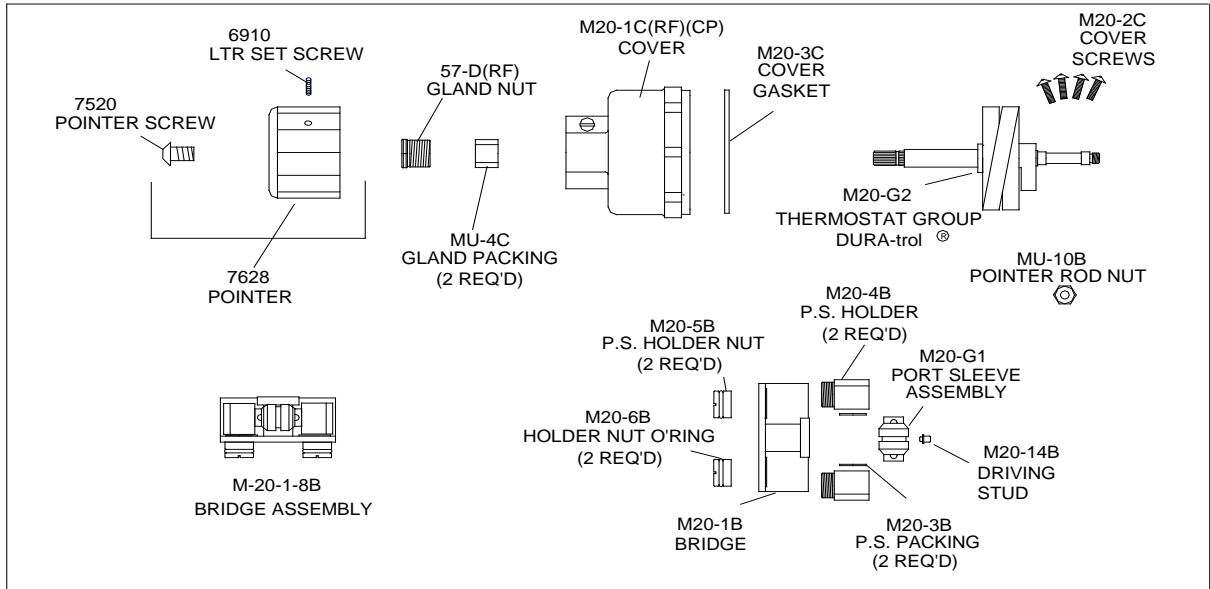

CHECKSTOP PARTS

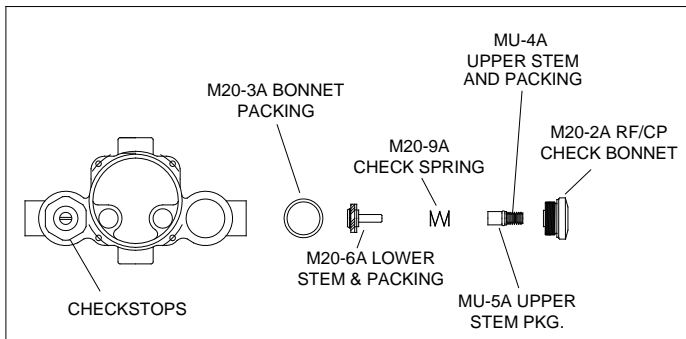

REPAIR KITS

REPAIR KIT 1/M20 PACKINGS & GASKETS

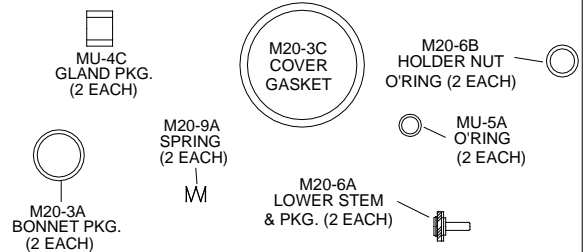

REPAIR KIT R/M20 REBUILDING KIT

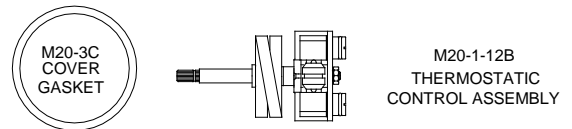

REPAIR KIT 4/M20 REBUILDING KIT

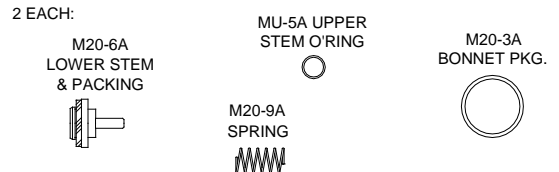

REPAIR KIT 2/M20 PORT SLEEVE KIT



REMEMBER! THIS IS A CONTROL DEVICE WHICH MUST BE CLEANED AND MAINTAINED ON A REGULAR BASIS (SEE MAINTENANCE GUIDE AND RECORD, MGR-1000).

NOTE: AFTER INSTALLING NEW PARTS IT WILL BE NECESSARY TO RESET THE ADJUSTABLE HIGH TEMPERATURE LIMIT STOP ON EACH VALVE (SEE PAGE 2).

**OPTIONAL OUTLET SETUP PIPING
(BY OTHERS)**

The addition of this piping arrangement (extra tee and ball valve) eliminates the need to turn showers on and off throughout the building at setup. The flows required in the setup instructions (page 3) are set by using Ball Valve A. (make sure main outlet ball valve is closed).

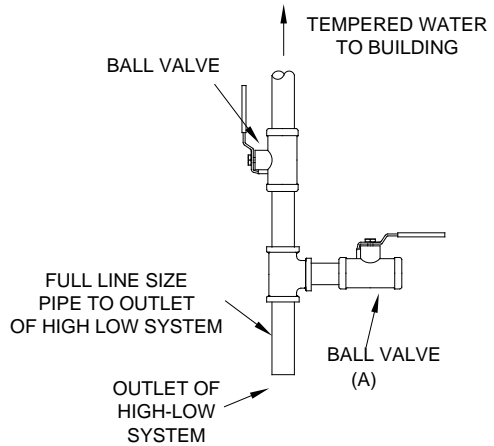

CAUTION! ALL THERMOSTATIC WATER MIXING VALVES AND SYSTEMS HAVE LIMITATIONS! THEY WILL NOT PROVIDE THE DESIRED PERFORMANCE OUTSIDE OF THEIR FLOW CAPACITY RANGE! CONSULT THE CAPACITY CHART BELOW AND OBSERVE MINIMUM FLOWS SHOWN.

FLOW CAPACITIES

MODEL	IN	OUT	MINIMUM FLOW (GPM) (l/min)	SYSTEM PRESSURE DROP (PSIG)										PSI
				5	10	15	20	25	30	35	40	45	50	
				,3	.7	.97	1.4	1.7	2.1	2.4	2.8	3.1	3.4	
TM-420A	3/4"	1"	1.0 (3.7)	12 45	18 68	22 83	26 98	30 114	33 125	36 136	39 148	42 159	44 167	GPM l/min

LIMITED WARRANTY

Leonard Valve Company (hereinafter, "Leonard") warrants the original purchaser that products manufactured by Leonard will be free from defects in material or workmanship under normal conditions of use, when properly installed and maintained in accordance with Leonard's instructions, for a period of one year from the date of shipment. During this period, Leonard will at its option repair or replace any product, or part thereof, which shall be returned, freight prepaid, to the Leonard factory and determined by Leonard to be defective in materials or workmanship. Leonard provides no warranty, express or implied, which extends beyond the description contained herein. LEONARD SPECIFICALLY DISCLAIMS ANY AND ALL IMPLIED WARRANTIES OF MERCHANTABILITY OR OF FITNESS FOR A PARTICULAR PURPOSE. Nonetheless, some jurisdictions may not allow the disclaimer of certain implied warranties, in which case Leonard hereby limits such implied warranties to the duration of the limited warranty period contained herein. Some jurisdictions may not allow limitations on how long an implied warranty lasts, so the foregoing durational limitation may not apply to you. In no event will Leonard be liable for labor or incidental or consequential damages. Any alteration or improper installation or use of this product will void this limited warranty. If any provision of this limited warranty is prohibited by law in the applicable jurisdiction, such provision shall be null and void, but the remainder of this limited warranty shall continue in full force and effect.

1360 Elmwood Avenue, Cranston, RI 02910 USA

Phone: 401.461.1200 Fax: 401.941.5310

Email: info@leonardvalve.com

Web Site: <http://www.leonardvalve.com>