

# HIGH LOW THERMOSTATIC MIXING VALVES

## XL-186-690-LF- \_\_\_\_\_ Cabinet Assembly

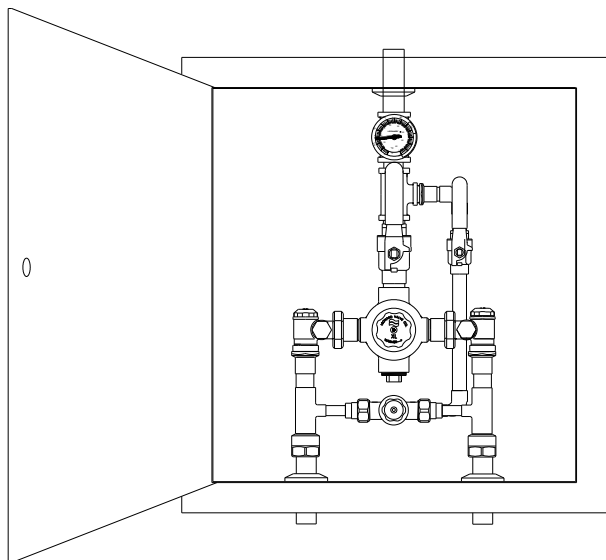

- High Low Thermostatic Water Mixing Valve with 0.5 GPM (1.9 l/min) minimum flow capacity, 1 GPM (3.8 l/min) to ASSE 1069
- 1" inlets, 1-1/4" outlet (25mm x 32 mm)
- Adjustable high temperature limit stop set for 120°F (49°C)
- Combination checkstops, unions, strainers on inlets wall support, Outlet volume control / shutoff
- Color coded dial thermometer (0 to 140°F, -10° to 60°C)
- Temperature adjustment range, 90-140°F (32-60°C) \*\*
- Bottom inlets, top outlet
- Factory assembled and tested
- Select valve piping finish and cabinet below
- See Flow Capacity Chart on reverse

### OPTIONS:

- SUFFIX IT** – Inlet thermometers (SHIP LOOSE) Exposed cabinet only
- SUFFIX BWE REC**- Steel cabinet, baked white enamel recessed
- SUFFIX STSTL REC**-Stainless Steel recessed cabinet
- SUFFIX BWE EXP**-Exposed cabinet, baked white enamel
- SUFFIX STSTL EXP**- Exposed cabinet, Stainless steel
- SUFFIX RHH** - Right hand hinge

Note: No SEMI-REC offered on 24" X 26" X 9" cabinet



**WARNING:** This product can expose you to chemicals including lead, which is known to the State of California to cause cancer. For more information, go to [www.P65Warnings.Ca.gov](http://www.P65Warnings.Ca.gov)

Valve assembly is certified to meet Low-Lead requirements of wetted surface area containing less than 0.25% lead by weight. All other fittings and components, the sum total of which comprise the wetted surface of this product contains less than one quarter of one percent of lead by weight.

ASSE 1069 CERTIFIED



CSA CERTIFIED



**\*\*NOTE:** For temperatures outside of this valve's stated range, please see our line of bi-metal valves.

NOTE: Leonard Valve Company reserves the right of product or design modification without notice or obligation

**\*NOTE:** A locking temperature regulator set for 120°F (49°C), is simply a mechanical setting to prevent unauthorized temperature set point changes. If incoming water is hotter than 150°F (65.5°C), the temperature of the factory test, the valve may deliver in excess of 120°F. **MUST BE RESET BY THE INSTALLER**

**NOTE: This product is not for potable use**

**Engineer's Approval**

Job # \_\_\_\_\_

Arch/Eng. \_\_\_\_\_

Contractor \_\_\_\_\_

Note: The model shown represents Leonard Products which are believed to be equivalent in type and function to items specified. Leonard Valve Company is not responsible for errors or omissions due to differences in interpretations of information provided.

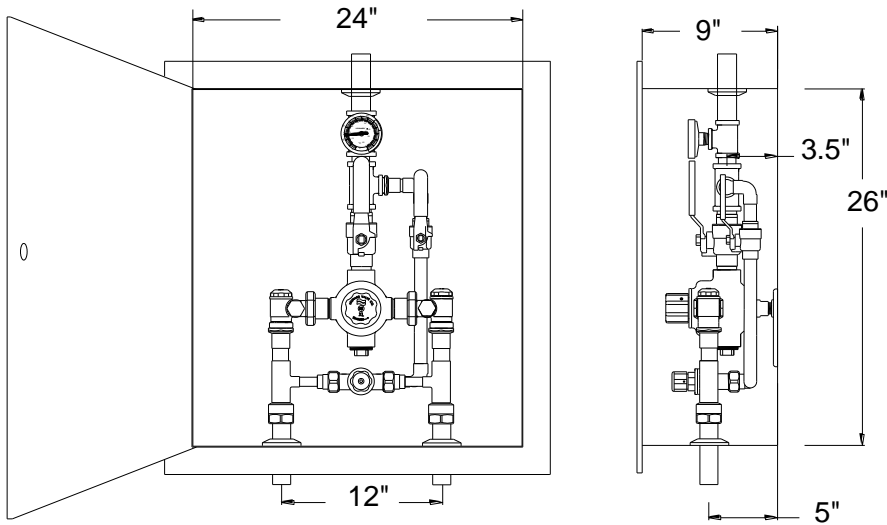

PRESSURE DROP													
MIN FLOW	5	10	15	20	25	30	35	40	45	50	55	60	PSI
	0.3	0.7	1	1.4	1.7	2.1	2.4	2.8	3.1	3.4	3.8	4.1	BAR
1	5	10	20	35	39	41	48	55	59	62	64	65	GPM
3.8	19	38	76	132	148	155	182	208	223	235	242	246	l/min

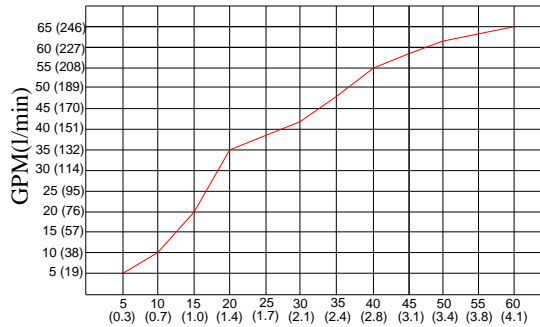

**PRESSURE DROP PSI(BAR)**

**LIMITED WARRANTY**

Leonard Valve Company (hereinafter, "Leonard") warrants the original purchaser that products manufactured by Leonard will be free from defects in material or workmanship under normal conditions of use, when properly installed and maintained in accordance with Leonard's instructions, for a period of one year from the date of shipment. During this period, Leonard will at its option repair or replace any product, or part thereof, which shall be returned, freight prepaid, to the Leonard factory and determined by Leonard to be defective in materials or workmanship. Leonard provides no warranty, express or implied, which extends beyond the description contained herein. LEONARD SPECIFICALLY DISCLAIMS ANY AND ALL IMPLIED WARRANTIES OF MERCHANTABILITY OR OF FITNESS FOR A PARTICULAR PURPOSE. Nonetheless, some jurisdictions may not allow the disclaimer of certain implied warranties, in which case Leonard hereby limits such implied warranties to the duration of the limited warranty period contained herein. Some jurisdictions may not allow limitations on how long an implied warranty lasts, so the foregoing durational limitation may not apply to you. In no event will Leonard be liable for labor or incidental or consequential damages. Any alteration or improper installation or use of this product will void this limited warranty. If any provision of this limited warranty is prohibited by law in the applicable jurisdiction, such provision shall be null and void, but the remainder of this limited warranty shall continue in full force and effect.

**CAUTION!** All thermostatic water mixing valves have limitations. They will NOT provide the desired accuracy outside of their flow capacity range. Consult the Flow Capacity Chart and DO NOT OVERSIZE. Minimum flow must be no less than as indicated.



1360 Elmwood Avenue, Cranston, RI 02910 USA

Phone: 401.461.1200 Fax: 401.941.5310

Email: [info@leonardvalve.com](mailto:info@leonardvalve.com)

Web Site: <http://www.leonardvalve.com>