

WALL MOUNTED SHOWER SYSTEMS

surfashower®

FOR HANDICAPPED
INSTALLATION



Pressure actuated SS-PAM-501P(G) (Shown)

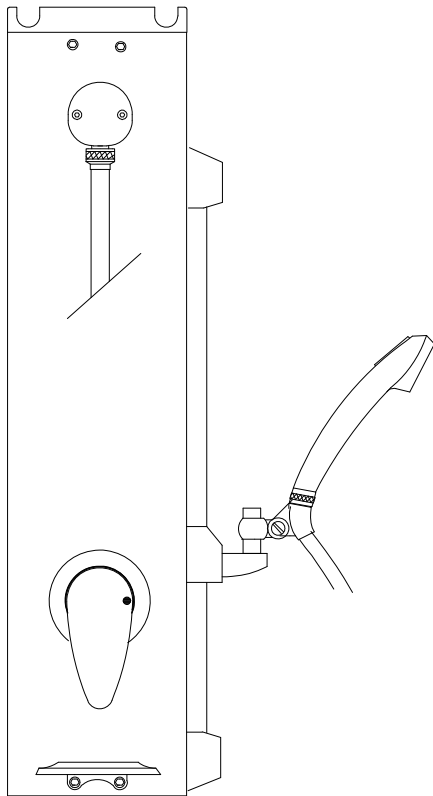

SS-PAM-501P(G) Pressure Actuated Surfashower®

- PAM®II Pressure Actuated Shower Mixer
- Stainless steel pressure balancing piston
- Built-in shutoff for single handle operation
- Maximum operating pressure: 125 PSI (860 KPA)
- Color-coded dial
- 501P(G) hand shower, 2.5 GPM (9.5 l/min.) max. flow rate, 69" (1753mm) hose, 24" (610mm) glide bar, double check valve assembly, supply elbow.
- Integral checkstops
- Factory pre-assembled with 18 gauge stainless steel cover, #4 finish, with sloping top cap and regular bottom caps.
- 1/2" flexible stainless steel hose on inlets.

OPTIONS:

- LHB-Left side bar
- QD- Quick disconnect fitting
- 500P-Hand shower 500P 2.5 GPM 69" hose with wall hook
- 501P(G)-30 hand shower, 2.5 GPM (9.5 l/min.) max. flow rate, 69" (1753mm) hose, 30" glide bar, double check valve
- SUFFIX 515P(G) - Hand spray, 69" braided stainless steel flex hose 24" glide rail, double check valve backflow preventer, supply elbow and flange operates at 1.50 GPM / 5.7 LPM, below ASME,ANSI A112.18.1 standard at 2.5 GPM/ 19.46 LPM
- SUFFIX 515P(G)-30 Same as above , with 30" bar
- SUFFIX INVB- Inline vacuum breaker
- VX- Integral stainless steel extension to ceiling, specify length. See reverse side to calculate VX length.

SS-PAM-501P(G)

VALVE IS ASSE LISTED

VALVE IS CSA LISTED



WARNING: This product can expose you to chemicals including lead, which is known to the State of California to cause cancer. For more information, go to www.P65Warnings.Ca.gov

Engineer's Approval	Job # _____
	Arch/Eng. _____
	Contractor _____



1360 Elmwood Avenue, Cranston, RI 02910 USA

Phone: 401.461.1200 Fax: 401.941.5310

Email: info@leonardvalve.com

Web Site: <http://www.leonardvalve.com>

WALL MOUNTED SHOWER SYSTEMS- Surfashower®

Pressure Actuated Model
 * SS-PAM-501P(G)

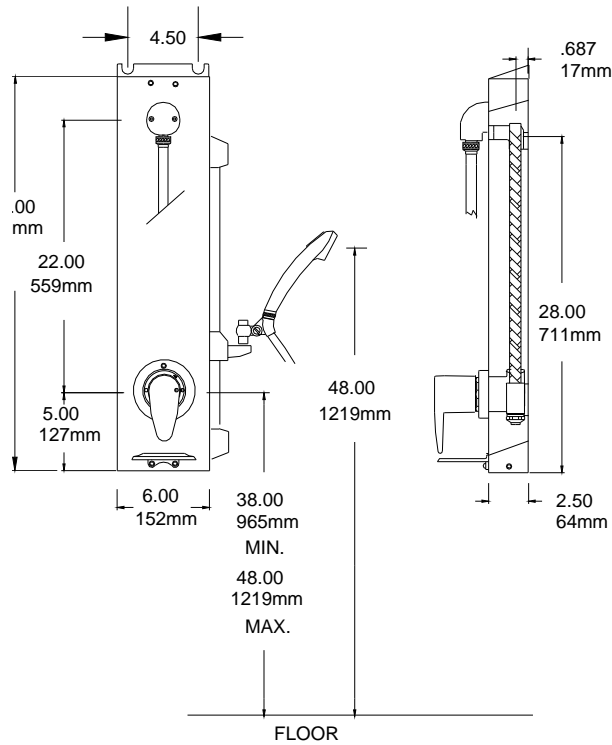

SUFFIX VX

**VX LENGTH= Ceiling height minus shower
 Valve height (38" (965mm) AFF min). minus 25"
 (624mm)**

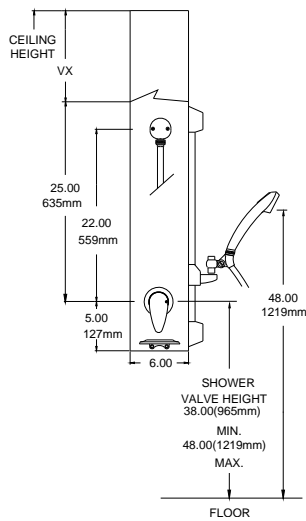

1360 Elmwood Avenue, Cranston, RI 02910 USA
 Phone: 401.461.1200 Fax: 401.941.5310
 Email: info@leonardvalve.com
 Web Site: <http://www.leonardvalve.com>