

INSTALLATION SETUP AND OPERATING INSTRUCTIONS THERMOSTATIC WATER MIXING VALVE SYSTEM TM-500, TM-550

IMPORTANT! Provide valve serial number (located on valve body) when ordering parts!!

Starting with EMV5500909

Compliance.....ANSI Z 358-1

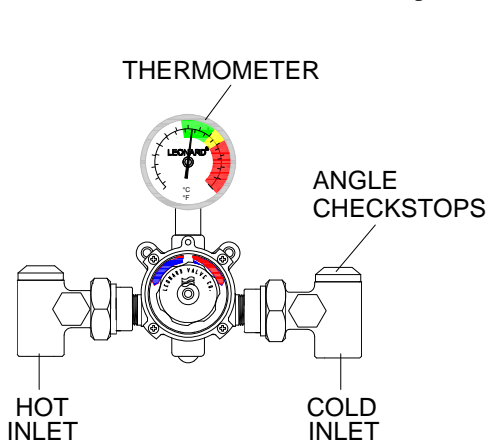

TM-500

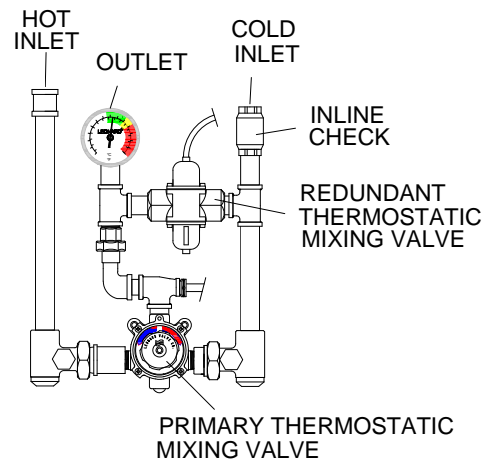

TM-550

INSTALLATION

<ol style="list-style-type: none"> 1. Valve should be installed at a location where it can easily be cleaned, adjusted or repaired. 2. The inlets are clearly marked on the valve body casting. Connect the hot water into the inlet marked "HOT" and cold water into the inlet marked "COLD." These are NOT to be confused with the "C-H" markings on the front cover. 	<ol style="list-style-type: none"> 3. The inlets are clearly marked on the valve body casting. Connect the hot water into the inlet marked "HOT" and cold water into the inlet marked "COLD." These are NOT to be confused with the "C-H" markings on the front cover. 4. Use solder or pipe cement sparingly. Supply pipes should be flushed before the valve is connected. Flush outlet pipe and valve as soon as it is connected. <p style="text-align: center;">Maximum Operating Pressure 125PSI (860 KPA) for Hot and Cold Water.</p>
--	---

NOTE: It may be necessary to recirculate the tempered water to the face/eyewash should the piping be exposed to excessive hot or cold conditions. Consult factory for proper piping.

CAUTION

IMPORTANT! These systems are designed to provide mixed water from 60 to 90°F (15 to 32°C) for eye/face wash applications only. Call Leonard for systems designed to operate at temperatures outside of this range.

REMEMBER! THIS IS A CONTROL SYSTEM WHICH MUST BE CLEANED AND MAINTAINED ON A REGULAR BASIS (SEE MAINTENANCE GUIDE AND RECORD MGR-1000).

1360 Elmwood Avenue, Cranston, RI 02910 USA

Phone: 401.461.1200 Fax: 401.941.5310

Email: info@leonardvalve.com

Web Site: <http://www.leonardvalve.com>

ADJUSTMENT AND SERVICE

Leonard Type TM Thermostatic Water Mixing Valves are simple in design and may be easily cleaned, adjusted and repaired. If the installation is accessible, servicing may be completed without disconnecting the valve.

Leonard Type TM Thermostatic Water Mixing Valves are simple in design and may be easily cleaned, adjusted and repaired. If the installation is accessible, servicing may be completed without disconnecting the valve.

TO RESET ADJUSTABLE HIGH TEMPERATURE LIMIT STOP:

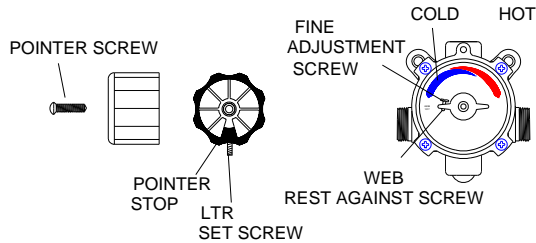

1. Loosen LTR Set Screw, remove POINTER SCREW.
2. Adjust POINTER to maximum desired temperature.
3. Remove POINTER, replace POINTER on spline rod with STOP (which is cast into the underside on the pointer), resting against the BOTTOM side of the WEB on the FINE ADJUSTMENT SCREW.
4. If fine adjustment is needed, adjust FINE ADJUSTMENT SCREW on the cover, loosen for hotter or tighten for cooler temperature.
5. Replace POINTER and check temperature, if set to desired temperature replace POINTER SCREW, and tighten LTR SET SCREW.
6. The new maximum temperature has now been set. Test this temperature by holding a thermometer under the flow of water to be certain it is as desired.

*** LIMIT STOP MUST BE RESET AND RECHECKED EACH TIME HANDLE IS REMOVED.**

WARNING

WARNING! This Thermostatic Mixing Valve has an adjustable high temperature limit stop, which must be checked. If temperature is too high, the installer **MUST RESET** this stop immediately. Always check the temperature of the mixed water when the lever handle is turned to full **HOT**. Excessively hot water is **DANGEROUS AND MAY CAUSE SCALDING!**

The high temperature limit stop is factory set at approximately 90°F (32°C) with an incoming hot water supply temperature of 135°F (57°C). If the incoming hot water on the job is higher than 135°F (57°C), the valve when turned to full hot will deliver water in excess of 90°F (32°C) and the high temperature limit stop **MUST BE RESET BY THE INSTALLER.**

TROUBLESHOOTING INSTRUCTIONS

PACKINGS & GASKETS	<ol style="list-style-type: none"> 1. Leak at pointer rod. 2. Leak between valve cover and base. 	PARTS REQUIRED: KIT#1/25 (PACKINGS & GASKETS)
PORT SLEEVE ASSEMBLY	<ol style="list-style-type: none"> 3. Valve delivers all cold water, or will not mix consistently. 	KIT#R/25M (REBUILDING KIT) OR TM25M-1-8B BRIDGE ASSEMBLY
THERMOSTAT GROUP	<ol style="list-style-type: none"> 4. After cleaning or replacing port sleeve assembly, valve will not hold temperature. 	KIT#R/25M (REBUILDING KIT) OR TM25M-G2 THERMOSTAT GROUP
CHECKSTOPS	<ol style="list-style-type: none"> 5. Hot water bypass into cold line. 6. Supplies cannot be shut off completely. 7. Leak at checkstop bonnet. 	KIT#2/25 (CHECKSTOP KIT)

SEE PAGE 5 FOR COMPLETE PARTS BREAKDOWN, PARTS KITS

Check for significant variations in outlet flow. Thermostatic valves will NOT provide the desired accuracy outside of their flow capacity range. Minimum flows must be no less than shown (see Flow Capacities, page 6).

If installed on a circulated hot water system, make certain the valve is piped according to Leonard Required Methods of Piping (see page 3).

REMEMBER! THIS IS A CONTROL DEVICE WHICH MUST BE CLEANED AND MAINTAINED ON A REGULAR BASIS. (SEE MAINTENANCE GUIDE AND RECORD, MGR-1000).

REQUIRED METHOD OF PIPING TM VALVE

METHOD #1

Required when hot water is to be circulated to a thermostatic mixing valve, which is a substantial distance from the hot water source.

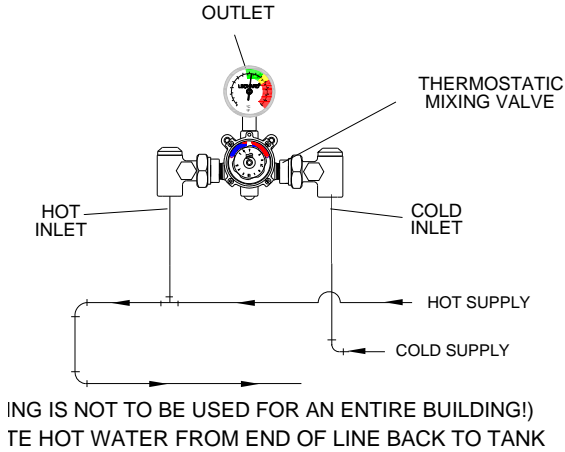

TM-500

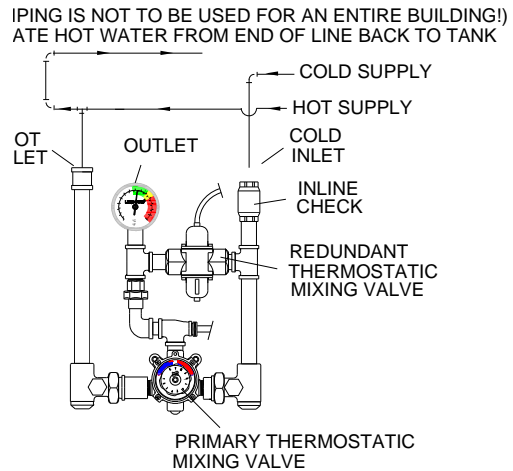

TM-550

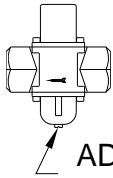

ADJUSTMENT SCREW

The TM-550 Redundant Thermostatic Mixing Valve has been factory set at 90°F (32°C). This set point can be field adjusted with a 3/8" wrench (see diagram). "Clockwise" direction will increase temperature. Maximum set point is 100°F (38°C).

REMEMBER! THIS IS A CONTROL DEVICE WHICH MUST BE CLEANED AND MAINTAINED ON A REGULAR BASIS. (SEE MAINTENANCE GUIDE AND RECORD, MGR-1000).

This unit must be cycled each time the emergency equipment is checked. See ANSI Z358.1, Maintenance and Training section:

Cycle redundant thermostatic valve by loosening the pointer set screw and setting the primary thermostatic mixing valve to full hot. (TM-550 only)

Check to be sure outlet temperature does not climb above 90°F (32°C)

Open eye/face wash and allow temperature to reach the set point.

Turn primary thermostatic mixing valve to full cold and wait ten seconds.

Turn primary thermostatic valve to full cold and wait ten seconds.

Set primary thermostatic mixing valve to the desired temperature and close eye/face wash.

Turn primary thermostatic valve to full hot and wait for ten seconds.

INSTRUCTIONS FOR DISMANTLING VALVE (DWG. 1)

1. Shut off hot and cold supplies to valve.
2. Remove four Cover Screws M-20-2C to release entire thermostatic control assembly.

WHEN RE-ASSEMBLING VALVE, insert Cover Gasket M-20-3C in base. Lubricate TM-28-6B O'Rings before re-inserting assembly.

After installing new parts, it will probably be necessary to reset high temperature limit. See instructions "TO RESET ADJUSTABLE HIGH TEMPERATURE LIMIT STOP" (page 2).

TO REMOVE BRIDGE ASSEMBLY (DWG. 2)

Remove MU-10B Pointer Rod Nut, remove TM25M-1-8B Bridge Assembly from pointer rod.

Failure to properly blend the water may be caused by a sticking condition in the TGM-1/25M Port Sleeve Assembly. The Thimble should slide freely on the Port Sleeve.

Clean with a NON-CORROSIVE CLEANING AGENT AND SOFT CLOTH. DO NOT USE ABRASIVES, then wash parts thoroughly.

To reassemble, replace Bridge Assembly on pointer rod. Driving ball on Thimble **MUST** engage hole in coil bracket. Replace pointer rod nut.

DO NOT apply grease or lubricants to the TGM-1/25M Port Sleeve Assembly.

TO DISASSEMBLE BRIDGE ASSEMBLY (DWG. 3)

Remove TM25-3A Holder Nuts using a screwdriver in the slots provided. Clean or replace TGM-1/25M Port Sleeve Assembly following instructions above. When reassembling, check TM25-3B port sleeve packings and replace if necessary.

TO CLEAN OR REPLACE THERMOSTAT GROUP

Remove stop retaining ring and stop. Loosen gland nut. Push rod through cover. BE CAREFUL NOT TO PULL THERMOSTAT COIL OUT OF SHAPE.

To clean, if a deposit has collected on the thermostat group, brush in a non-corrosive cleaning solution. Rinse in clean water and replace in cover with parts as shown.

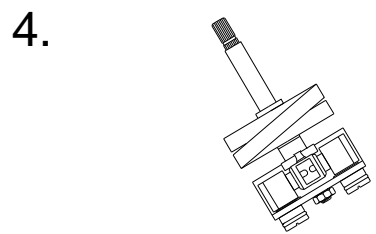
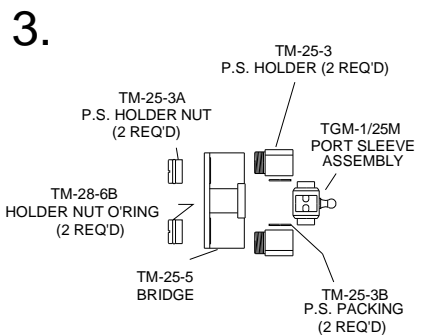
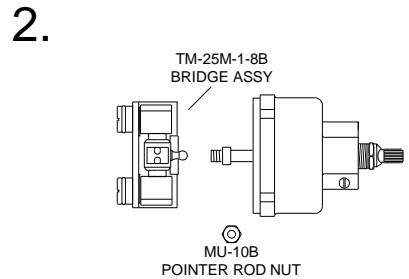
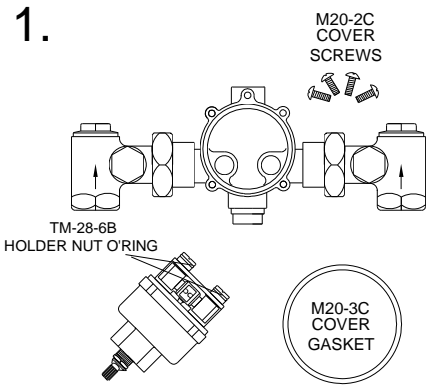

To replace entire Thermostatic Control Assembly specify TM-25M-1-12B

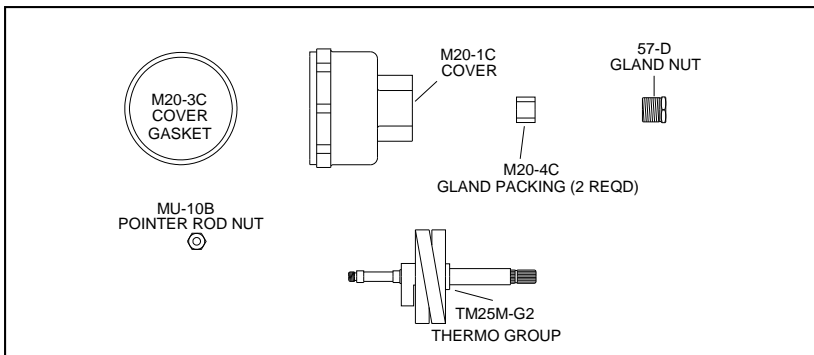

NOTE: AFTER INSTALLING NEW PARTS IT WILL BE NECESSARY TO RESET THE ADJUSTABLE HIGH TEMPERATURE LIMIT STOP (SEE PAGE 2).

REMEMBER: THIS IS A CONTROL DEVICE, WHICH MUST BE CLEANED ON A REGULAR BASIS (SEE MAINTENANCE GUIDE AND RECORD, MGR-1001).

TM-500, 550 VALVE PARTS

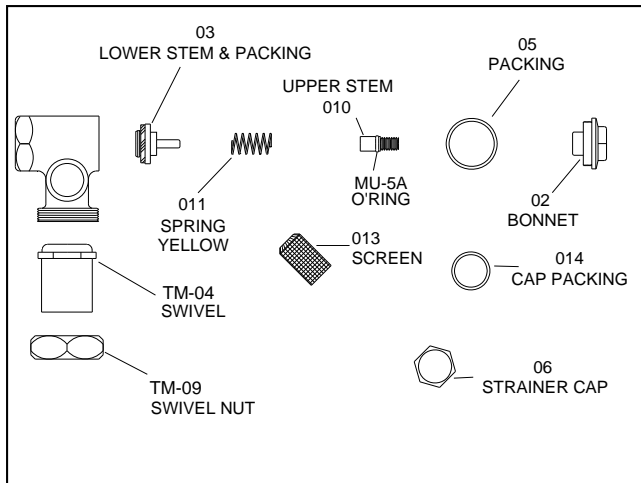
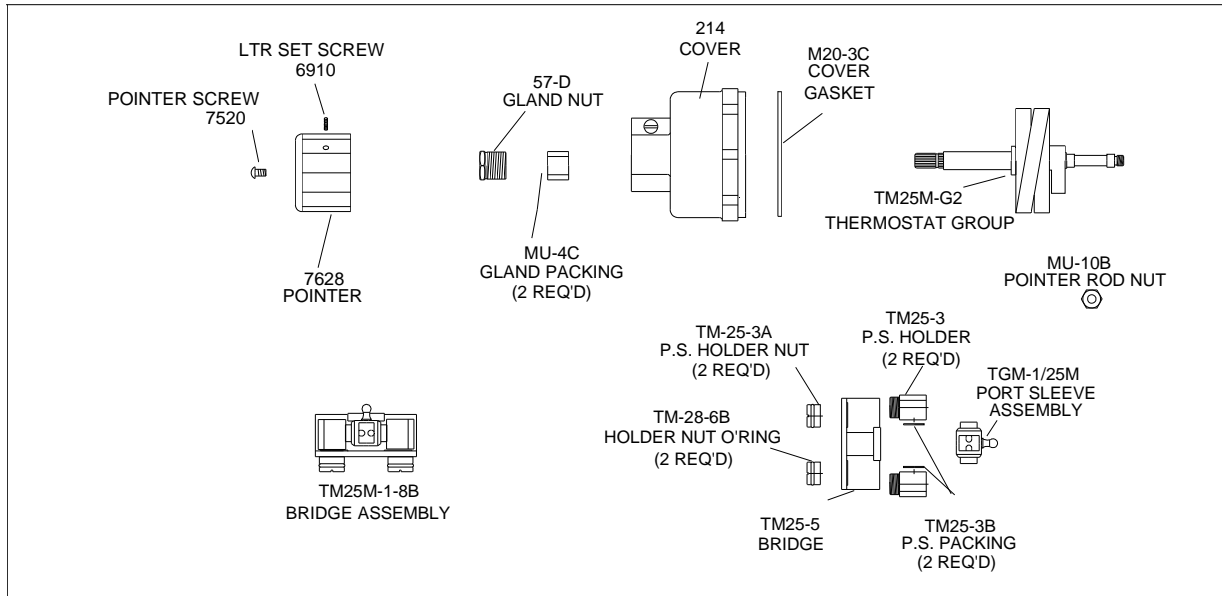

TO CLEAN THERMOSTAT GROUP

Push rod through cover. Be careful not to pull coil out of shape. If a deposit has collected on the thermostat group (TM25M-G2) brush in a non-corrosive cleaning solution.

REMEMBER! THIS IS A CONTROL DEVICE WHICH MUST BE CLEANED AND MAINTAINED ON A REGULAR BASIS (SEE MAINTENANCE GUIDE AND RECORD, MGR-1000).

NOTE: AFTER INSTALLING NEW PARTS IT WILL BE NECESSARY TO RESET THE ADJUSTABLE HIGH TEMPERATURE LIMIT STOP ON EACH VALVE (SEE PAGE 2).

KIT 1/25 PACKINGS & GASKETS

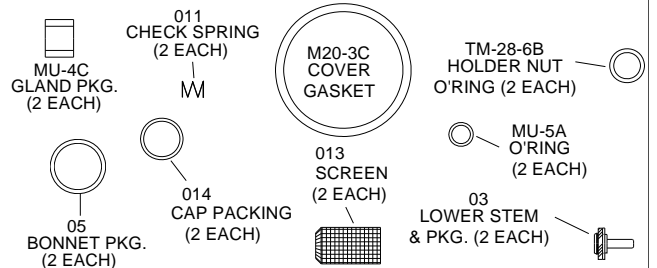

KIT R/25M REBUILDING KIT

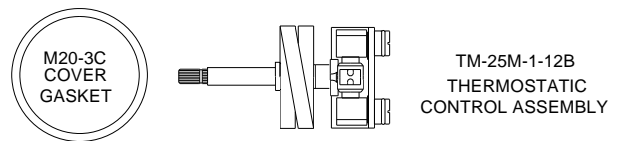

KIT 2/25 REBUILDING KIT

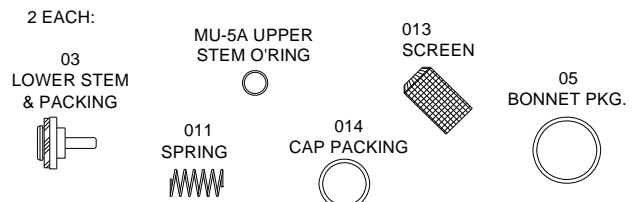

FLOW CAPACITIES

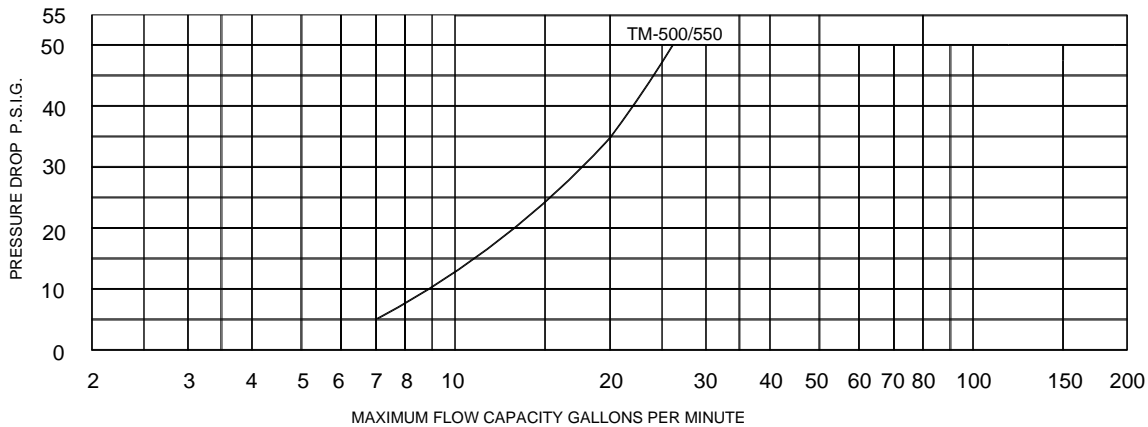

CAUTION! All thermostatic water mixing valves have limitations. They will not provide the desired accuracy outside of their flow capacity range. Consult the capacity chart and **DO NOT OVERSIZE**. Minimum flow must be no less than shown below.

IMPORTANT! These systems are designed to provide mixed water from 60 to 90°F (15 to 32°C) for face/eyewash applications only. Call Leonard for systems designed to operate at temperatures outside of this range.

MODEL	IN	OUT	MINIMUM FLOW (GPM) L/MIN	INTERNAL COLD WATER BY-PASS MINIMUM	SYSTEM PRESSURE DROP										PSI BAR
					5	10	15	20	25	30	35	40	45	50	
TM-500	3/4"	3/4"	3.0	8	7	9	12	13	16	18	20	22	24	26	GPM
			11	30	26	34	45	49	61	68	76	83	91	98	L/MIN
TM-550	3/4"	3/4"	3.0	8	7	9	12	13	16	18	20	22	24	26	GPM
			11	30	26	34	45	49	61	68	76	83	91	98	L/MIN
MAXIMUM FLOW CAPACITY															

LIMITED WARRANTY

Leonard Valve Company warrants the original purchaser that products manufactured by them (not by others) will be free from defects in materials and workmanship under normal conditions of use, when properly installed and maintained in accordance with Leonard Valve Company's instructions, for a period of one year from date of shipment. During this period the Leonard Valve Company will at its option repair or replace any product, or part thereof, which shall be returned, freight prepaid, to the Leonard factory and determined by Leonard to be defective in materials or workmanship. There are no warranties, express or implied, which extend beyond the description contained herein. There are no implied warranties of merchantability or of fitness for a particular purpose. In no event will Leonard be liable for labor or incidental or consequential damages. Any alteration or improper installation or use of the product will void this limited warranty.