

PNV-150-LF-2PS

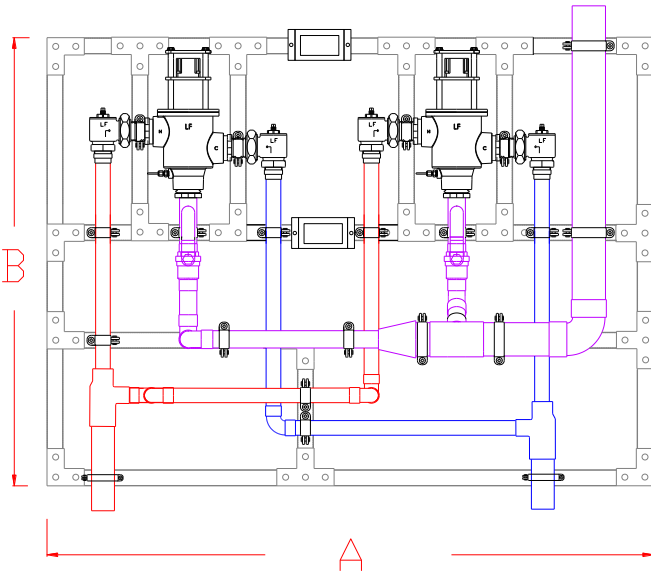

A = 54" ± 4" B = 42" ± 4"

NOTE: Options may change dimensions



- Two Digital Mixing Valves with check stops, integral RTD Sensors
- 2" inlets, 3" outlet (51mm X 76mm)
- 0.25 GPM** (.95 L/min) minimum flow capacity each
- Maximum operating pressure: 125 PSIG (860 KPA)
- Controls water temperature to ± 2°F in accordance with ASSE 1017
- Controls water temperature to ± 2°F during times of low / no system demand
- Automatic Hot/Cold Water shutoff upon cold/ hot water inlet supply failure
- User programmable set point range between 65°F and 180°F
- UL Listed Control Box
- UL Listed 120V plug in power supply with 6' cord
- Simple/intuitive user commissioning and setup
- Factory assembled and tested

This product meets Low Lead requirements of wetted surface area containing less than 0.25% lead by weight

****NOTE:** Each valve will maintain temperature with 0.25 GPM flow from the domestic hot water loop when properly installed near the hot water source with a continuously operating recirculation pump.

OPTIONS:

- ___ **IOT** – Internet of Things, Modbus to Wi-Fi gateway that connects to the Cloud to allow online monitoring of outlet temperature and Modbus connectivity to BMS
- ___ **BPS** – Back-up Power Supply, uninterruptable power supply with up to 2 hours run time in case of primary power loss

Valves are ASSE 1017 Certified



Valves are CSA Certified



Valve electronics are UL Certified



Product is non-cancellable and non-returnable from date of order with factory. Signed submittal required with purchase order.



WARNING: This product can expose you to chemicals including lead, which is known to the State of California to cause cancer. For more information, go to



www.P65Warnings.Ca.gov

1360 Elmwood Avenue, Cranston, RI 02910 USA

Phone: 401.461.1200 Fax: 401.941.5310

Email: info@leonardvalve.com

Web Site: <http://www.leonardvalve.com>

Single Valve Flow Capacity shown, Double flow rate when both valves are running

MINIMUM FLOW (GPM) (l/min)	PRESSURE DROP										PSI BAR
	5	⑩	⑮	⑳	25	30	35	40	45	50	
0.25** (0.95)**	50	72	86	100	115	122	136	140	158	165	GPM l/min
	.3	.7	.97	1.4	1.7	2.1	2.4	2.8	3.1	3.4	

HIGH TEMPERATURE FIXTURES (IF APPLICABLE)

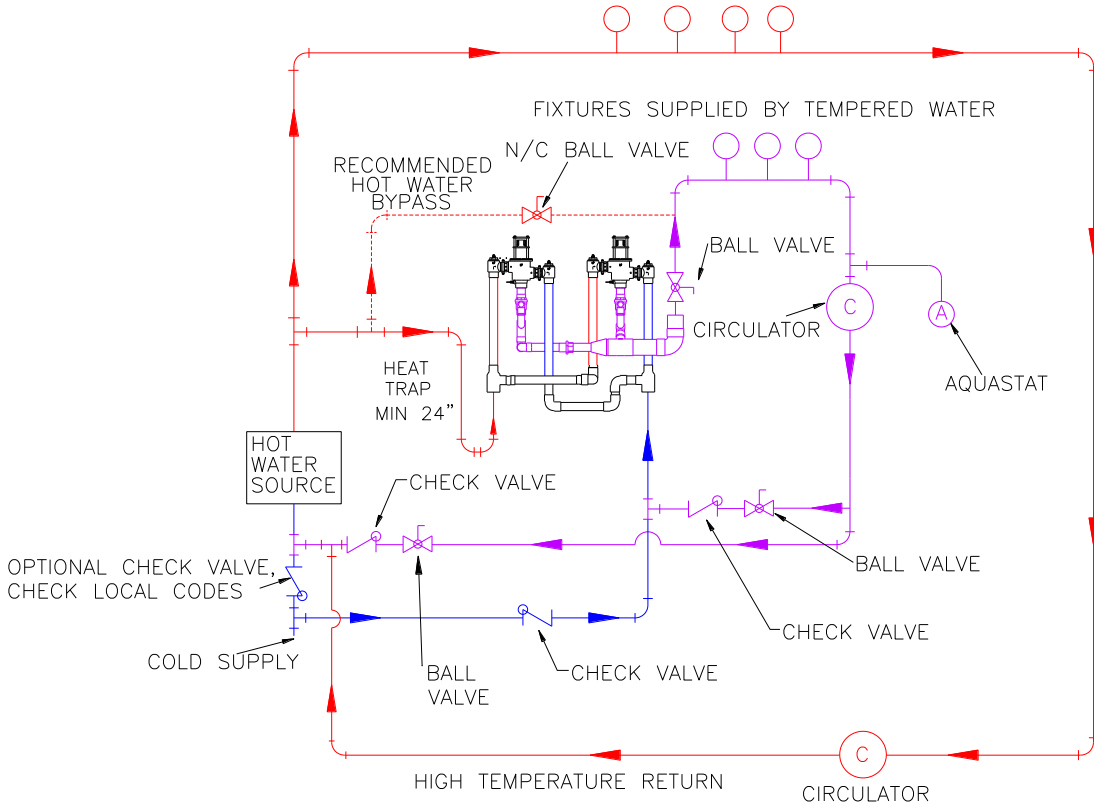

CAUTION! All thermostatic water mixing valves have limitations. They will NOT provide the desired accuracy outside of their flow capacity range. Consult the Flow Capacity Chart and DO NOT OVERSIZE. Minimum flow must be no less than as indicated.

NOTE: Flow rates will vary depending on existing field conditions. Leonard Valve Company always recommends using CASPAK® sizing software for proper valve sizing and model number applications.

Engineer's Approval

Job # _____

Arch/Eng. _____

Contractor _____

Note: The models shown represent Leonard Products which are believed to be equivalent in type and function to items specified. Leonard Valve Company is not responsible for errors or omissions due to differences in interpretations of information provided.

Note: Leonard Valve Company reserves the right of product, or design modifications without notice or obligation.



1360 Elmwood Avenue, Cranston, RI 02910 USA

Phone: 401.461.1200 Fax: 401.941.5310

Email: info@leonardvalve.com

Web Site: <http://www.leonardvalve.com>