

INSTALLATION ADJUSTMENT SERVICE HIGH CAPACITY MANIFOLD SYSTEM TM-186-20015020-PRV

IMPORTANT! Provide valve serial numbers (stamped on cover of valves) when ordering parts!!

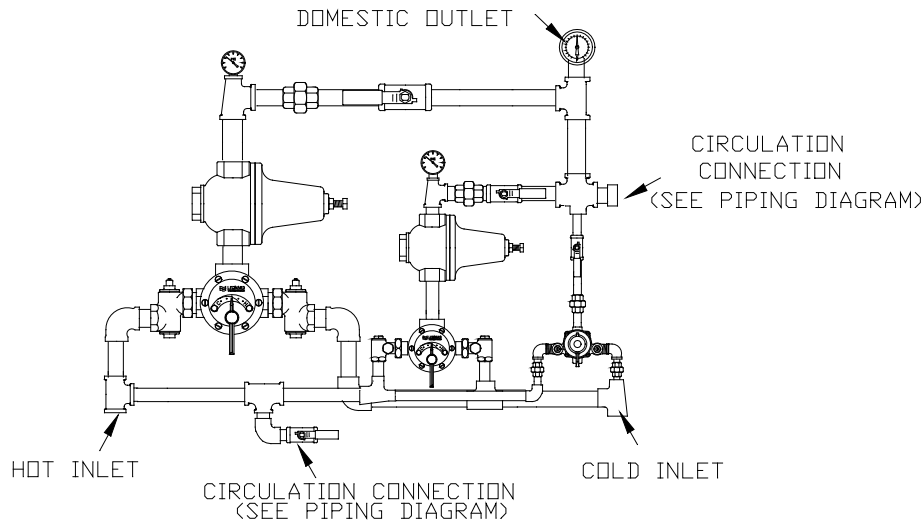

WARNING: This product can expose you to chemicals including lead, which is known to the State of California to cause cancer. For more information, go to www.P65Warnings.Ca.gov

INSTALLATION

1. Type TM manifold systems are factory pre-assembled and tested and include large and small thermostatic water mixing valves which function as a system to meet both high and low demand for tempered water.
2. System should be installed at a location where it can easily be cleaned, adjusted or repaired.
3. System supplies must be connected as shown (Hot-left, Cold-right). Exercise caution when soldering.
4. Flush pipes thoroughly after system has been connected.
5. If this assembly is installed on a recirculated hot water system it **MUST** be piped according to a **REQUIRED PIPING METHOD** (see page 4).
6. Refer to page 3 of this bulletin for correct Setup Instructions.
7. Please see page 8 troubleshooting pressure regulating valve **FOR OPERATING PRESSURES BELOW 30 PSI AND ABOVE 80 PSI**

Maximum Operating Pressure 125PSI (860 KPA) for Hot and Cold Water.

CAUTION

All thermostatic water mixing valves have limitations. They will not provide the desired accuracy outside of their flow capacity range. Consult the capacity chart on page 8. Minimum flow must be no less than as shown.

REMEMBER! THIS IS A CONTROL SYSTEM WHICH MUST BE CLEANED AND MAINTAINED ON A REGULAR BASIS (SEE MAINTENANCE GUIDE AND RECORD MGR-1000).

ADJUSTMENT AND SERVICE

Leonard Type TM Thermostatic Water Mixing Valves are simple in design and may be easily cleaned, adjusted and repaired. If the installation is accessible, servicing may be completed without disconnecting the valves.

NOTE: High Low Manifold Systems include Thermostatic Water Mixing Valves, which must be regularly maintained to provide best performance. Frequency of cleaning depends on quality of local water conditions and usage. See Maintenance Guide and Record MGR-1000.

WARNING

These mixing valves are equipped with an adjustable high temperature limit stop factory set at approximately 120°F (49°C) with an incoming hot water supply temperature of 150°F (65.5°C). If the hot water supply temperature of the job is greater than 150°F (65.5°C), the valves when turned to full HOT will deliver water in excess of 120°F (49°C) and the limit stops **MUST BE RESET BY THE INSTALLER!**

TO RESET ADJUSTABLE HIGH TEMPERATURE LIMIT STOP:

LARGE MIXING VALVE (TM-200 OR 150)

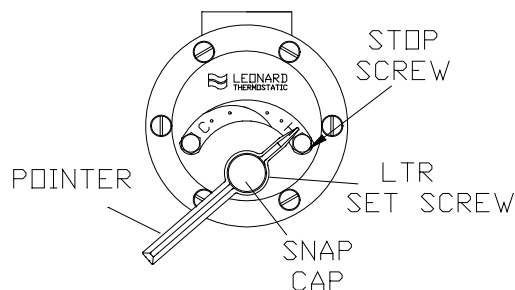

1. Loosen LTR set screw.
2. Remove SNAP CAP, SCREW & WASHER. Remove POINTER.
3. Temporarily place POINTER on the spline rod. Turn RIGHT for warmer temperature, turn LEFT for cooler temperature. When valve is delivering warmest temperature desired, remove the pointer.
4. Replace POINTER on the spline rod so that its RIGHT edge is resting against the STOP SCREW located on the RIGHT SIDE OF THE COVER.
5. The new maximum temperature has now been set. Test this temperature by holding a thermometer under the flow of water to be certain it is as desired.

SMALL MIXING VALVE (TM-20)

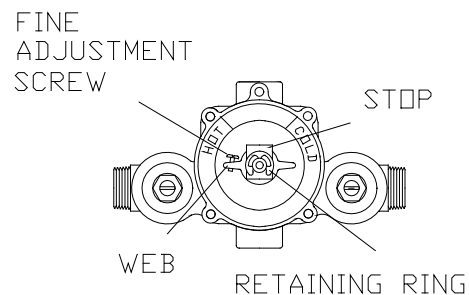

1. Loosen LTR set screw. Remove Snap cap and HANDLE, RETAINING RING and STOP
2. Temporarily place POINTER on the spline rod. turn LEFT for warmer temperature, turn RIGHT for cooler temperature. When valve is delivering warmest temperature desired, remove the pointer.
3. Push stop on rod so that its LEFT edge is resting against the fine adjustment screw on cover.
4. Turn fine adjustment screw, if necessary (clockwise for slightly higher temperature, counter clockwise for slightly lower temperature).
5. The new maximum temperature has now been set. Test this temperature by holding a thermometer under the flow of water to be certain it is as desired.

IMPORTANT! ALL THREE MIXING VALVES MUST BE SET AT THE SAME OPERATING TEMPERATURE.

SEE PAGES: 6 & 7 FOR COMPLETE PARTS BREAKDOWNS

Check for significant variations in outlet flow. Thermostatic valves will NOT provide the desired accuracy outside of their flow capacity range. Minimum flows must be no less than shown (see Flow Capacities, page 8).

If installed on a recirculated hot water system, make certain the valve is piped according to Leonard Required Piping Method (see page 4).

REMEMBER! THIS IS A CONTROL DEVICE WHICH MUST BE CLEANED AND MAINTAINED ON A REGULAR BASIS. (SEE MAINTENANCE GUIDE AND RECORD, MGR-1000).

SETUP INSTRUCTIONS

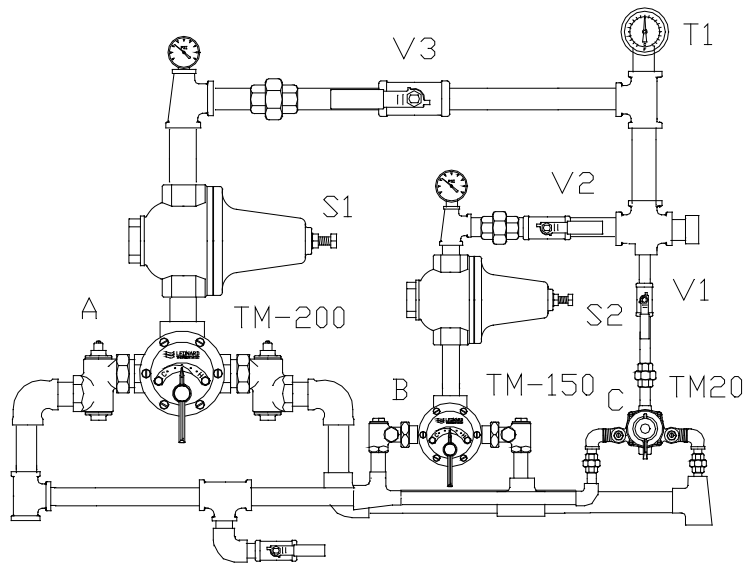

1. TM-186-PRV High-Low Unit **Must** be piped in accordance with appropriate Piping Method shown on page 4, if installed within a recirculated system.
2. Make sure hot and cold supplies to this assembly are fully operational.
3. Shut down circulator pumps.
4. Open at least (20) showers, or 50 GPM flow, (each in the full 'hot' position) downstream of this assembly.
5. Close outlet valves V1 and V2 of the smaller thermostatic water mixing valves labeled B and C.
6. Make sure outlet valve V3 on thermostatic water mixing valve A is in the full open position.
7. Set outlet temperature of mixing valve A to the safe required level (read temperature on gauge T1).
8. Set the thermostatic water mixing valves B and C to the full 'COLD' position.
9. Close all but (9) showers or reduce to 23 GPM (keep each shower in the full 'HOT' position) downstream of the assembly.
10. Open outlet valve V2 (V3 should still be open) and note the temperature on gauge T1.
11. Carefully adjust nut S1 at the PRV (pressure regulating valve) until the temperature drops approximately 20°F (see thermometer T1). Turn nut S1 clockwise if temperature dropped more than 20°F or turn nut S1 counterclockwise if temperature dropped less than 20°F.
12. Shut outlet valve V3
13. Set outlet temperature of mixing valve labeled B to the same temperature as originally set for mixing valve A (read temperature at gauge T1).
14. Close all but (2) showers or 5 GPM flow (keep each shower in the full 'HOT' position) downstream of the assembly.
15. Open outlet valve V1 (V2 should still be open) and note the temperature on gauge T1.
16. Carefully adjust nut S2 at the PRV (pressure regulating valve) until the temperature drops approximately 20°F (see thermometer T1). Turn nut S2 clockwise if temperature dropped more than 20°F or turn nut S2 counterclockwise if temperature dropped less than 20°F.
17. Shut outlet valve labeled V2 (V3 should already be closed).
18. Set outlet temperature of mixing valve labeled C to the same temperature as mixing valves A and B (read temperature at gauge T1).
19. Open outlet valves V2 and V3. System is operational.
20. Turn circulator pumps on. Important! Now proceed to balance recirculated tempered water system (see page 4).

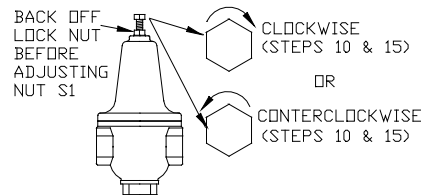

METHOD #4

NOTE: THIS PIPING METHOD IS USED FOR MODERATE FLOW SYSTEMS WHERE THE CIRCULATED FLOW IS EIGHT (8) TO TWENTY FIVE (25) GPM.

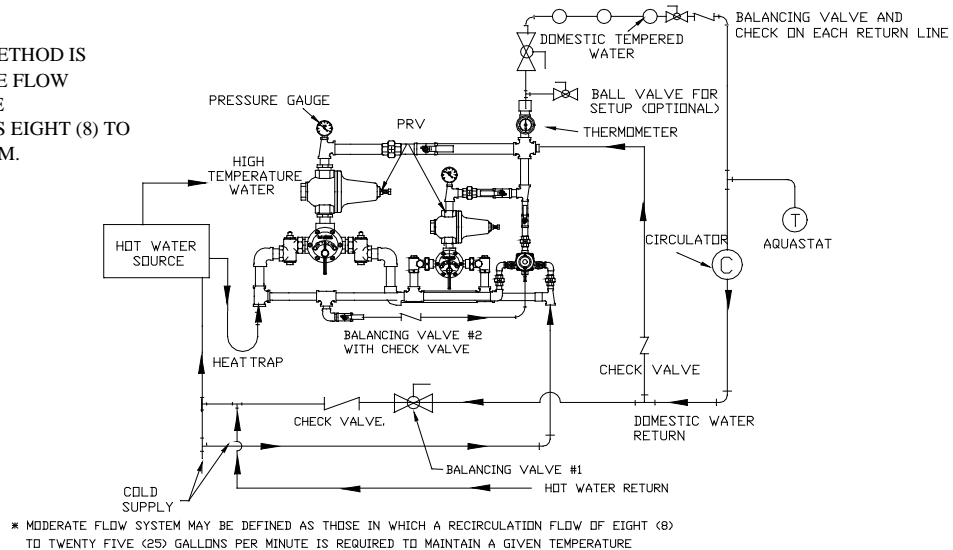

PROCEDURE TO BALANCE SYSTEM:

1. MAKE SURE NO WATER IS BEING DRAWN. OPEN BALANCING VALVE #1 AND #2 APPROX. 1/2 WAY AND START CIRCULATOR.
2. OBSERVE TEMPERATURE UNTIL IT STABILIZES.
3. CLOSE BALANCING VALVE #1 SLIGHTLY IF TEMPERATURE IS TOO HOT, OR OPEN IT SLIGHTLY IF TEMPERATURE IS TOO COLD AND ALLOW TEMPERATURE TO STABILIZE. REPEAT UNTIL DESIRED RECIRCULATED TEMPERATURE IS SET.
4. IF UNABLE TO REACH DESIRED TEMPERATURE OPEN BALANCING VALVE #2 COMPLETELY, REPEAT STEPS 2 & 3.

METHOD #5

NOTE: THIS PIPING METHOD IS USED FOR HIGH FLOW SYSTEMS WHERE THE CIRCULATED FLOW IS TWENTY FIVE (25) GPM OR GREATER.

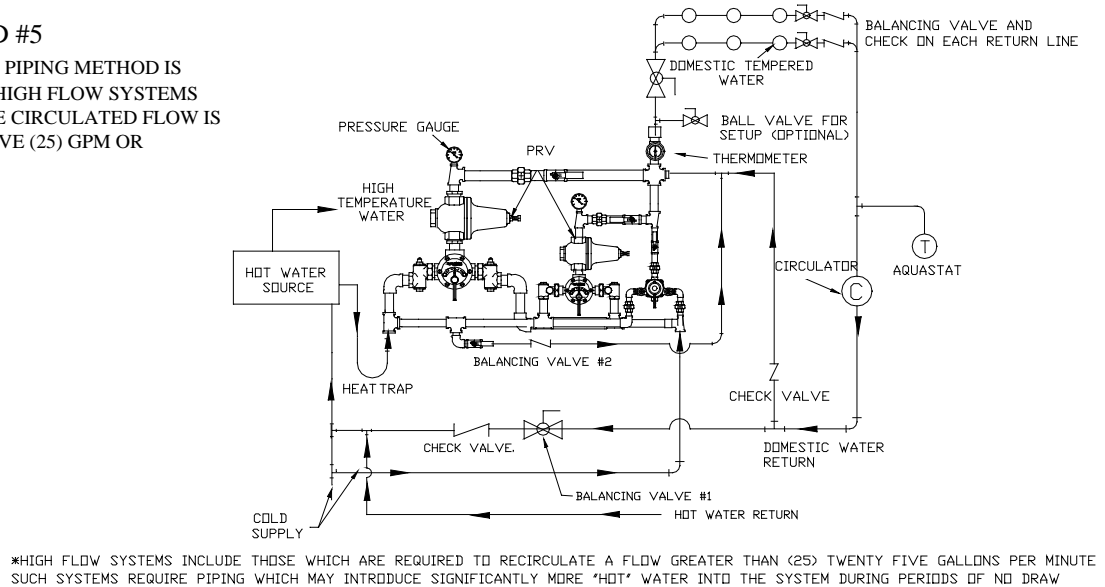

PROCEDURE TO BALANCE SYSTEM:

1. MAKE SURE NO WATER IS BEING DRAWN. OPEN BALANCING VALVE #1 AND #2 APPROX. 1/2 WAY AND START CIRCULATOR.
2. OBSERVE TEMPERATURE UNTIL IT STABILIZES.
3. CLOSE BALANCING VALVE #1 SLIGHTLY IF TEMPERATURE IS TOO HOT, OR OPEN IT SLIGHTLY IF TEMPERATURE IS TOO COLD AND ALLOW TEMPERATURE TO STABILIZE. REPEAT UNTIL DESIRED RECIRCULATED TEMPERATURE IS SET.
4. IF UNABLE TO REACH DESIRED TEMPERATURE OPEN BALANCING VALVE #2 COMPLETELY, REPEAT STEPS 2 & 3.

CONTACT LEONARD FOR ADDITIONAL PIPING METHODS DESIGNED FOR LOWER FLOW RECIRCULATED SYSTEMS AND FOR OTHER SPECIAL INSTALLATIONS.

INSTRUCTIONS FOR SERVICING SMALL TM VALVE

1. Shut off hot and cold supplies to this valve. Remove snap cap, screw and washer, loosen LTR set screw, and then remove friction spring and pointer.
2. Remove, cover screws, and cover, to which the thermostat group is attached.

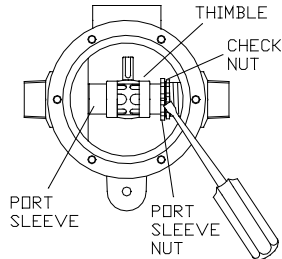
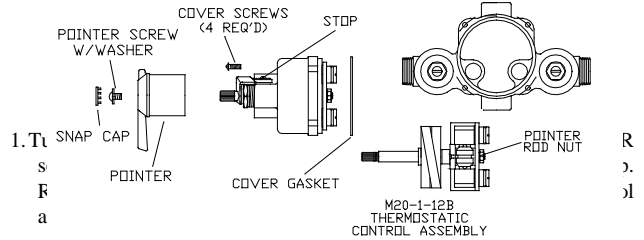

3. To clean port sleeve assembly (the thimble must slide freely on the port sleeve): unscrew the check nut as far as it will go, then screw the port sleeve nut into the base. The port sleeve and thimble may then be lifted out. There is no shoulder for the TM-150 port sleeve.
4. Clean with a non-corrosive cleaning solution. **DO NOT USE ABRASIVES!** The port sleeve should be reassembled in the valve with the shoulder to the left.
5. To clean thermostat group brush in a non-corrosive cleaning solution.
6. When reassembling, make sure driving ball of thermostat group engages the ball socket of the port sleeve assembly.

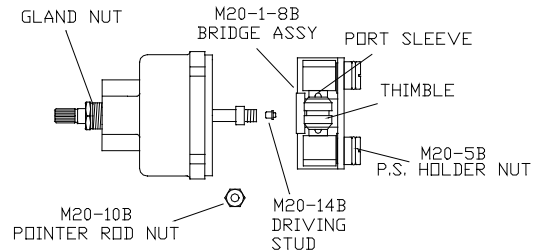

2. To remove bridge assembly, M20-1-8B, remove pointer rod nut (M20-10B) and pull bridge assembly off control rod. Do not misplace M20-14B driving stud.
3. To clean, submerge bridge assembly in clean water or non-corrosive cleaning solution. **Do not use abrasives!** Be certain thimble moves freely on port sleeve. Note! Driving stud (M20-14B) must engage slot in thimble when reassembling.
4. To clean thermostat group, loosen gland nut and remove cover. Brush in a non-corrosive cleaning solution.
5. To disassemble bridge assembly, see drawing page 7 (remove M20-5B holder nuts with screwdriver in slots provided).

TROUBLESHOOTING INSTRUCTIONS

Note: Provide valve serial number when ordering parts for either valve!

TROUBLESHOOTING INSTRUCTIONS			
Note: Provide valve serial number when ordering parts for either valve!			
PACKING & GASKETS	<ol style="list-style-type: none"> 1. Leaks at stem. 2. Leak between valve cover and base. 	Large Valve: Kit # 1/____ ("200" For TM200, "125" for TM-150)	Small Valve: Kit # 1/M20 (Packings & Gaskets)
PORT SLEEVE/BRIDGE ASSEMBLY	<ol style="list-style-type: none"> 3. Valve delivers either all hot or all cold water, or will not mix consistently. 	Kit # R/____ ("200" for TM- 200, "125" for TM-150) or TGM-1/____ ("200" or "125")	Kit #R/M20 (Rebuilding Kit) or M20-1-8B Bridge Assembly
THERMOSTAT GROUP	<ol style="list-style-type: none"> 4. After cleaning or replacing port sleeve/bridge assembly, valve performance is not consistent. 	Kit # R/____ ("200" or "125") or TGM-2/____ ("200" or "125")	Kit #R/M20 (Rebuilding Kit) or M20-G2 Thermostat Group
CHECKSTOPS	<ol style="list-style-type: none"> 5. Hot water by-pass into cold line (or cold into hot). 5. Supplies cannot be shut off completely. Supplies leak at checkstop bonnets. 	Kit #4/____ ("200" for TM- 200, "125" for TM-150)	Kit #4/M20 (Checkstop Kit)

See pages 6 & 7 for Parts Breakdowns

TM-200 VALVE PARTS

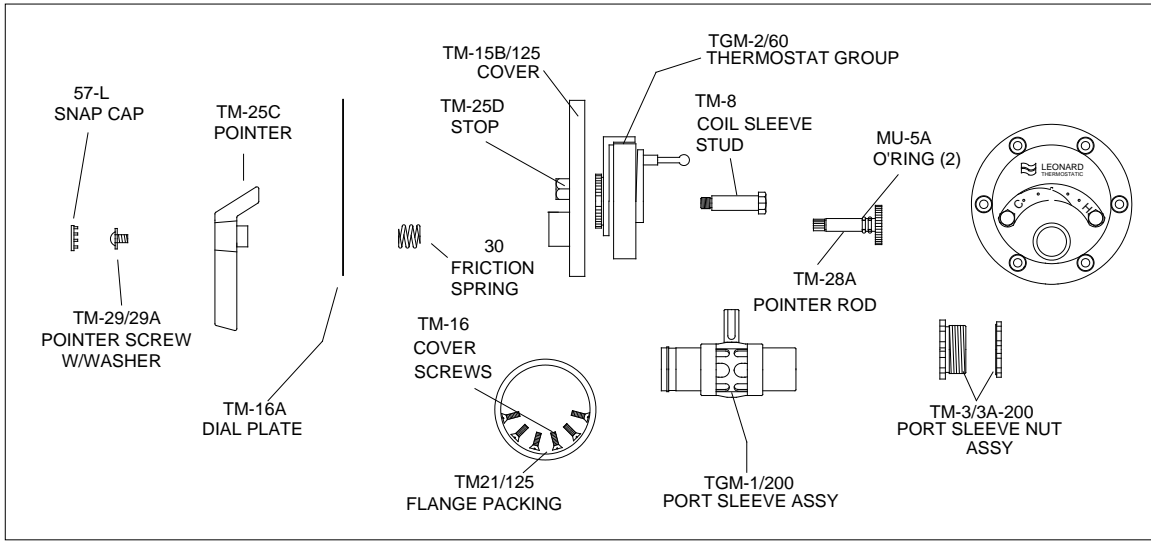

CHECKSTOP PARTS

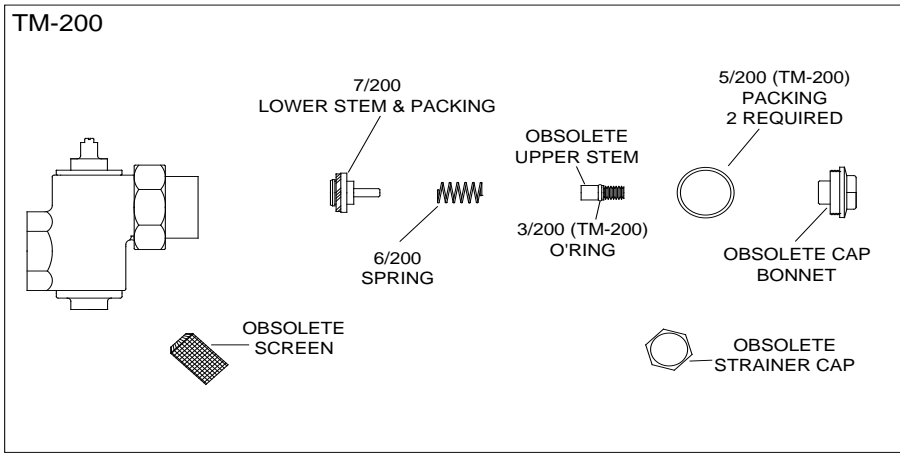

LOCK TYPE POINTER

TM valves are furnished with lockable pointers.

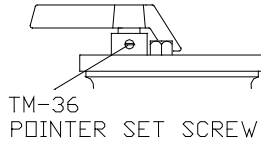

REPAIR KITS

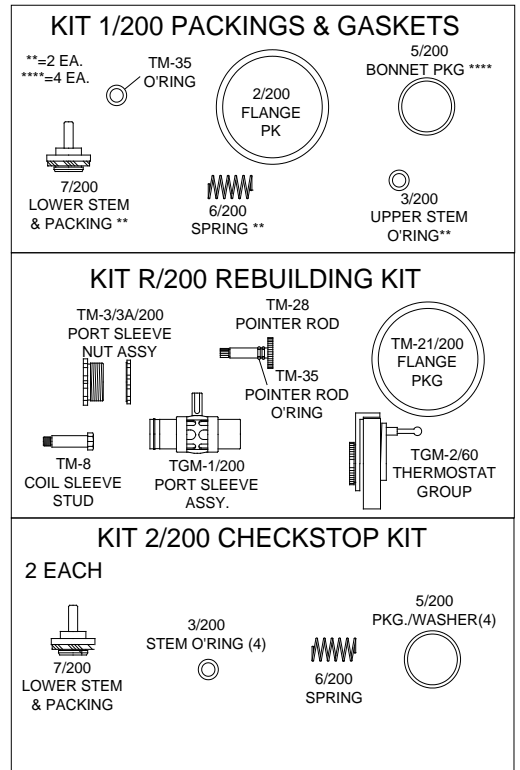

REMEMBER! THIS IS A CONTROL DEVICE WHICH MUST BE CLEANED AND MAINTAINED ON A REGULAR BASIS (SEE MAINTENANCE GUIDE AND RECORD, MGR-1000).

NOTE: AFTER INSTALLING NEW PARTS IT WILL BE NECESSARY TO RESET THE ADJUSTABLE HIGH TEMPERATURE LIMIT STOP ON EACH VALVE (SEE PAGE2).

TM-150 VALVE PARTS

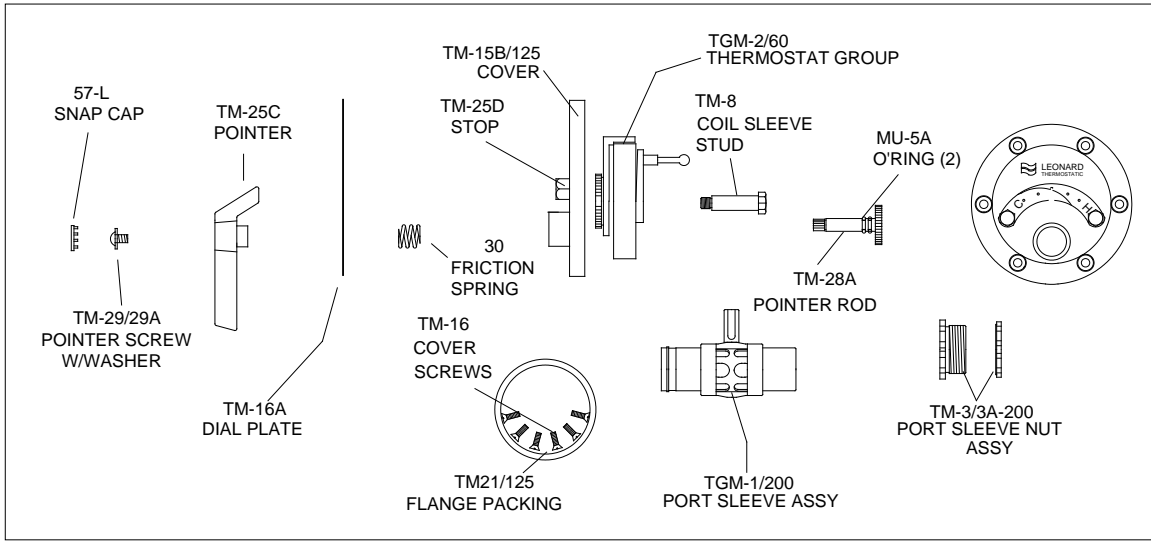

CHECKSTOP PARTS

REPAIR KITS

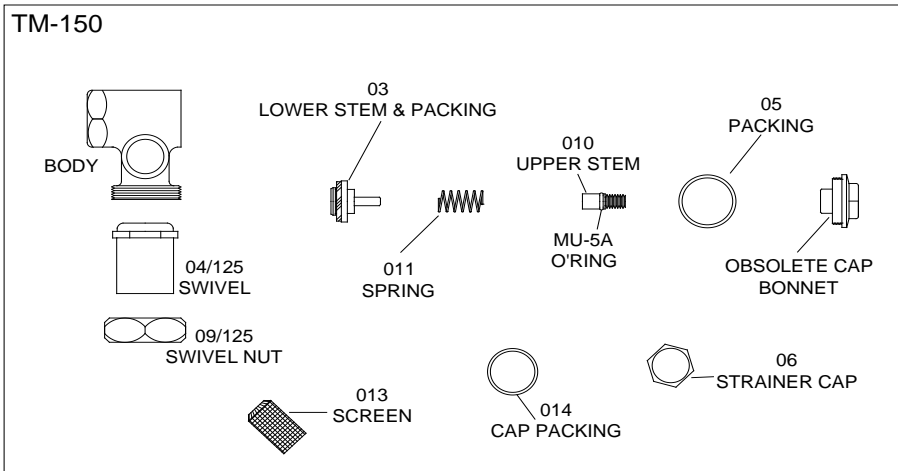

KIT 1/125 PACKINGS & GASKETS
 **=2 EA.

- MU-5A O'RING 4 REQD
- TM-21/125 FLANGE PK
- BONNET PKG **
- 03 LOWER STEM & PACKING **
- 014 CAP PACKING**
- 011 SPRING **
- 013 SCREEN**

KIT R/125 REBUILDING KIT

- TM-3/125 PORT SLEEVE NUT ASSY
- TM-28A POINTER ROD
- TM-21/125 FLANGE PKG
- TM-8 COIL SLEEVE STUD
- TGM-1/125 PORT SLEEVE ASSY.
- MU-5A POINTER ROD O'RING 2 REQD.
- TGM-2/60 THERMOSTAT GROUP

KIT 2/125 CHECKSTOP KIT
 2 EACH

- MU-5A STEM O'RING
- 011 SPRING
- 05 BONNET PKG.
- 03 LOWER STEM & PACKING
- 014 CAP PACKING
- 013 SCREEN

LOCK TYPE POINTER

TM valves are furnished with lockable pointers.

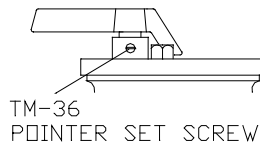

REMEMBER! THIS IS A CONTROL DEVICE WHICH MUST BE CLEANED AND MAINTAINED ON A REGULAR BASIS (SEE MAINTENANCE GUIDE AND RECORD, MGR-1000).

NOTE: AFTER INSTALLING NEW PARTS IT WILL BE NECESSARY TO RESET THE ADJUSTABLE HIGH TEMPERATURE LIMIT STOP ON EACH VALVE (SEE PAGE2).

SMALL TM VALVE PARTS

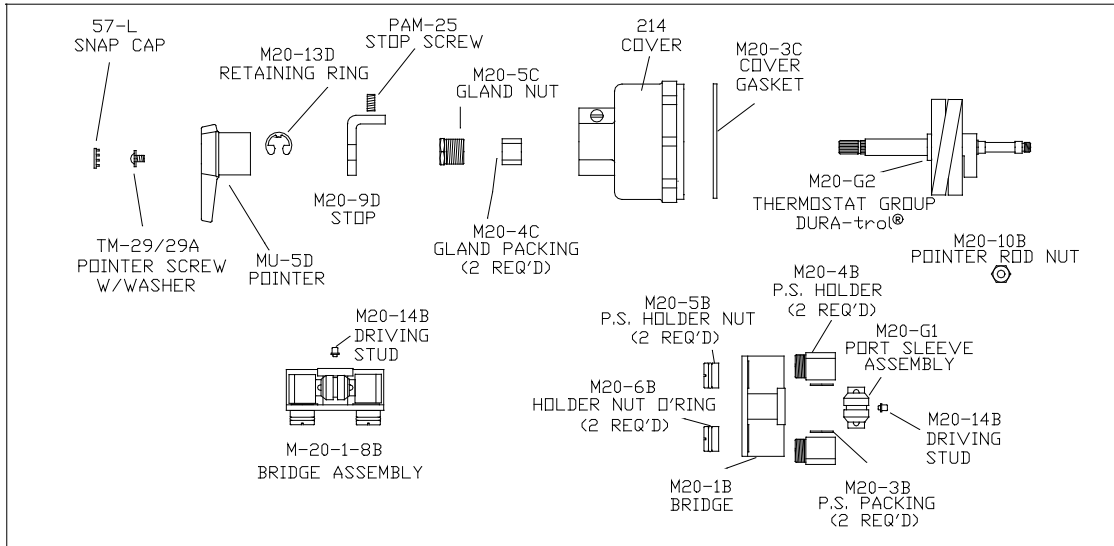

CHECKSTOP PARTS

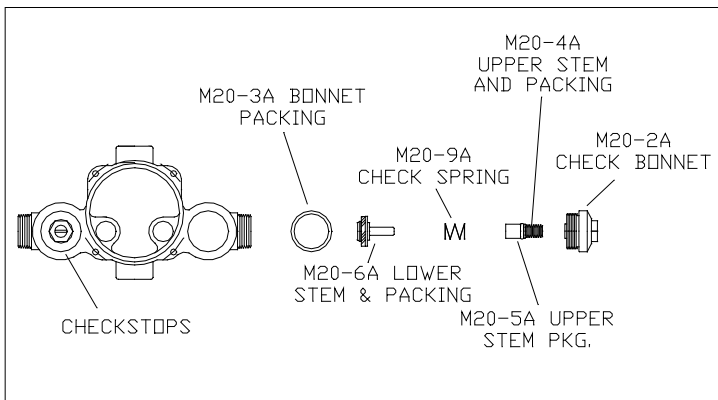

LOCK-TYPE POINTER

TM valves are furnished with lockable pointers. See part noted.

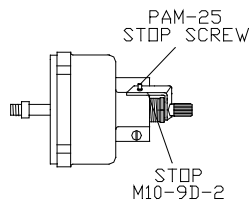

REPAIR KIT

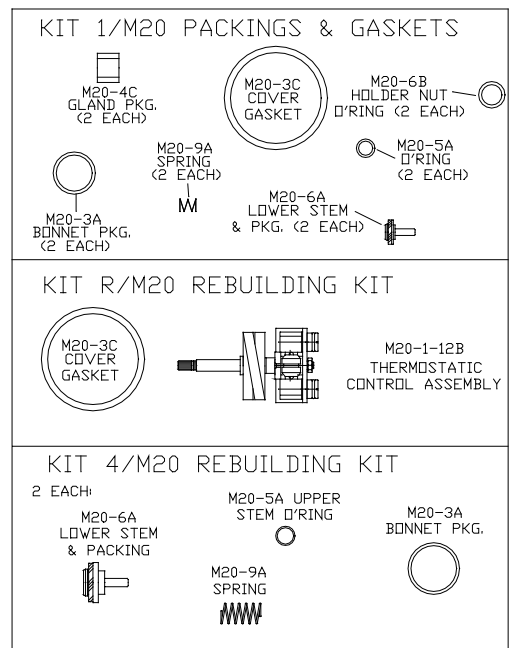

REMEMBER! THIS IS A CONTROL DEVICE WHICH MUST BE CLEANED AND MAINTAINED ON A REGULAR BASIS (SEE MAINTENANCE GUIDE AND RECORD, MGR-1000).

NOTE: AFTER INSTALLING NEW PARTS IT WILL BE NECESSARY TO RESET THE ADJUSTABLE HIGH TEMPERATURE LIMIT STOP ON EACH VALVE (SEE PAGE 2).

**OPTIONAL OUTLET SETUP PIPING
(BY OTHERS)**

The addition of this piping arrangement (extra tee and ball valve) eliminates the need to turn showers (or equivalent flow) on and off throughout the building at setup. The flows required in the setup instructions (page 3) are set by using Ball Valve A. (make sure main outlet ball valve is closed).

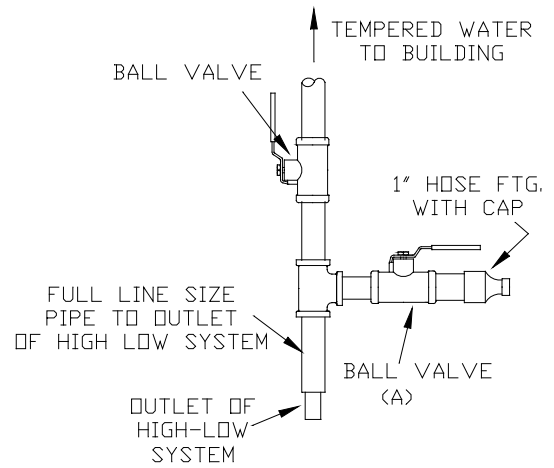

CAUTION! ALL THERMOSTATIC WATER MIXING VALVES AND SYSTEMS HAVE LIMITATIONS! THEY WILL NOT PROVIDE THE DESIRED PERFORMANCE OUTSIDE OF THEIR FLOW CAPACITY RANGE! CONSULT THE CAPACITY CHART BELOW AND OBSERVE MINIMUM FLOWS SHOWN.

FLOW CAPACITIES

MODEL	IN	OUT	MINIMUM FLOW (GPM) L/MIN	SYSTEM PRESSURE DROP										PSI BAR
				5	10	15	20	25	30	35	40	45	50	
TM-186- 20015020PRV	3"	3"	1.0	160	210	250	275	305	325	340	345	348	350	GPM
	76mm	76mm	3.7	606	795	946	1041	1154	1230	1287	1306	1317	1325	L/MIN

TROUBLESHOOTING PRESSURE REGULATING VALVE

When replacement parts are required for the pressure regulating valve, the following information must be given:

Manufacturer of PRV: _____
 Type: _____
 Serial number: _____

(This information is found on the tag attached to the adjusting screw).

SYMPTOM:

1. If PRV leaks by adjusting screw or if no pressure adjustment is possible.
2. If low pressure in building
3. If outlet pressure has to be 70 to 100 PSI

Repair Kit:
Kit R/PRV

Low Pressure Spring LP/PRV
High Pressure Spring HP/PRV

LIMITED WARRANTY

Leonard Valve Company warrants the original purchaser that products manufactured by them (not by others) will be free from defects in materials and workmanship under normal conditions of use, when properly installed and maintained in accordance with Leonard Valve Company's instructions, for a period of one year from date of shipment. During this period the Leonard Valve Company will at its option repair or replace any product, or part thereof, which shall be returned, freight prepaid, to the Leonard factory and determined by Leonard to be defective in materials or workmanship. There are no warranties, express or implied, which extend beyond the description contained herein. There are no implied warranties of merchantability or of fitness for a particular purpose. In no event will Leonard be liable for labor or incidental or consequential damages. Any alteration or improper installation or use of the product will void this limited warranty.