

EMERGENCY MIXING VALVES

ECO-MIX™

Mixing Valve for Eye/Face Wash Units

2 - 9 GPM (7.6 - 34 l/min) flow rate
up to 45 PSI (3.1 bar) system pressure drop

6020-LF

ASSE 1071 Certified



CSA Certified

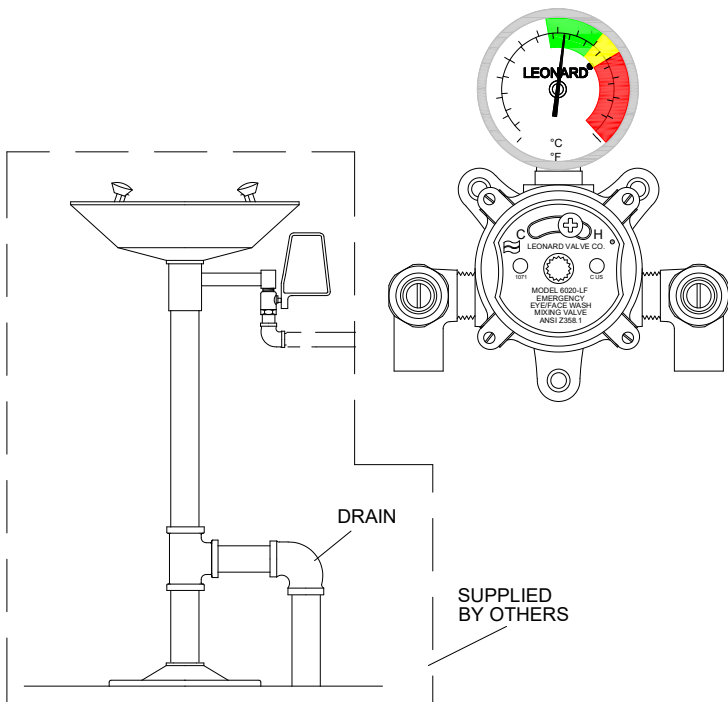

- DURA-trol® solid bimetal thermostat directly linked to valve porting to control the intake of hot and cold water and compensate for supply temperature and pressure fluctuations. DURA-trol® is highly responsive and cannot be damaged by extremes in temperature.
- Thermostatic Mixing Valve can be set to the correct temperature for the application.
- Locking temperature regulator to prevent accidental movement set for 85°F (29°C)
- Mixing valve will close down on failure of cold water supply
- Mixing valve with special internal cold water bypass capable of a minimum of 4 GPM (15 l/min) @ 30 PSI (2.1 Bar) upon failure of hot water supply
- Adjustable high temperature limit stop * set for 90°F (32°C)
- Integral wall support
- Threaded ½" top or bottom inlets
- Threaded ½" top outlet
- Rough bronze finish
- Dial thermometer (range 0 to 140°F, -10 to 60°C)
- Angle checkstops on inlets
- Compliance.....ANSI Z358.1
- Maximum supply temperature 180 °F (82°C)
- Maximum supply pressure 125 PSI (8.6 Bar)

This product is certified to meet Low Lead requirements of wetted surface area containing less than 0.25% lead by weight



WARNING: Risk of cancer and reproductive harm from exposure to lead – See www.P65Warnings.ca.gov

Engineer's Approval	Job # _____
	Arch/Eng. _____
	Contractor _____

OPTIONS:

- ___ CP- Chrome plated finish (threaded inlets and outlet)
- ___ IT- Inlet thermometers (0 to 140°F, -10 to 60°C)

CABINET OPTIONS – SEE PAGE 3

*NOTE: A limit stop, set for 90°F (32°C), is simply a mechanical setting to prevent excessive handle rotation. If incoming water is hotter than 135°F (57°C), the temperature of the factory test, the valve when turned to full HOT may deliver water in excess of 90°F and the limit stop MUST BE RESET BY THE INSTALLER



1360 Elmwood Avenue, Cranston, RI 02910 USA
Phone: 401.461.1200 Fax: 401.941.5310
Email: info@leonardvalve.com
Web Site: <http://www.leonardvalve.com>

EMERGENCY WATER MIXING VALVE FOR EYE/FACE WASH

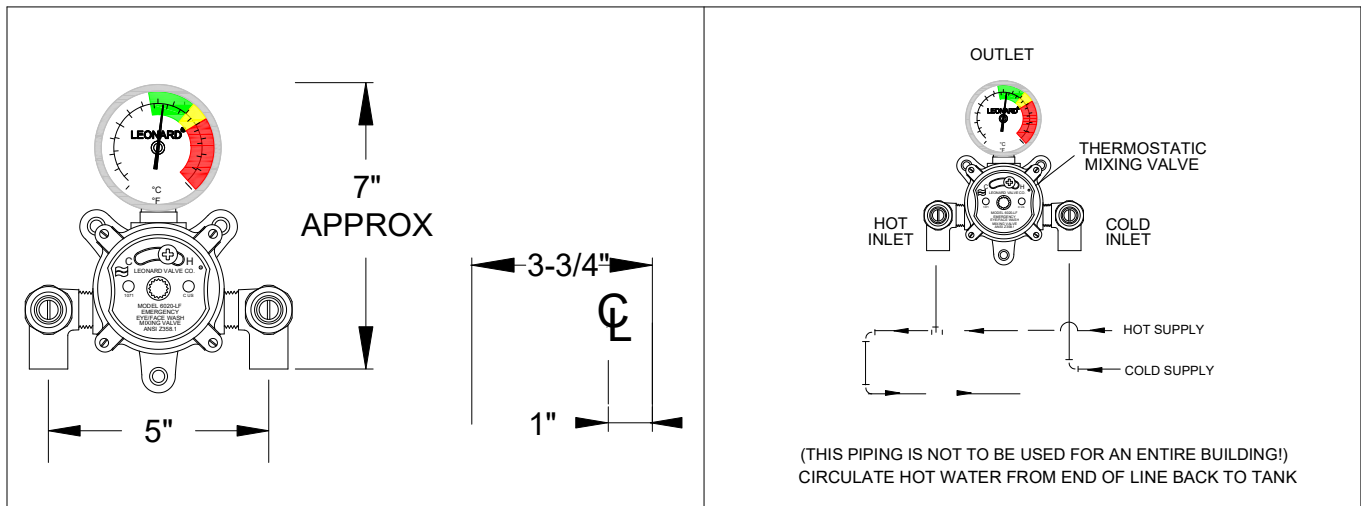

CAUTION! It may be necessary to recirculate the tempered water to the eye/face wash should the piping be exposed to excessive hot or cold conditions. Consult factory for proper piping.

FLOW CAPACITIES

MODEL	IN	OUT	MINIMUM FLOW (GPM)	INTERNAL COLD WATER BY-PASS MINIMUM	PRESSURE DROP									
					5	10	15	20	25	30	35	40	45	PSI
			L/MIN		0.3	0.7	1.0	1.4	1.7	2.1	2.4	2.8	3.1	BAR
6020-LF	1/2"	1/2"	2.0	4	2.0	2.7	3.5	4.5	5.5	6.5	7.5	8.5	9.0	GPM
			7.6	15	7.6	10	13	17	21	25	28	32	34	L/MIN
MAXIMUM FLOW CAPACITY														

The Emergency eye/face wash Mixing Valve shall control and maintain the temperature of the water to the station. Unit shall be self contained and include a thermostatic water mixing valve, a dial thermometer on the outlet, angle checkstops, wall mounting bracket, piping and fittings factory assembled and tested, top or bottom inlets and top outlet, unit set for 85°F (29°C) and a maximum temperature of 90°F (32°C). Unit must be able to be set to the correct temperature for the specific contaminant but must be locked in place to prevent changing of the temperature by accident. Unit must be checked weekly for performance in conjunction with the requirements of ANSI Z358.1. Unit shall be able to flow a minimum flow of 4 GPM (15 l/min) at 30 PSI (2.1 Bar).

WARNING! IT IS THE RESPONSIBILITY OF THE SPECIFIER TO DETERMINE THE DELIVERED WATER TEMPERATURE TO EACH SAFETY FIXTURE. A COMFORTABLE RANGE IS 60°F TO 90°F (15° TO 32°C). IN CIRCUMSTANCES WHERE A CHEMICAL REACTION IS ACCELERATED BY WATER TEMPERATURE, A MEDICAL ADVISOR SHOULD BE CONSULTED FOR THE OPTIMUM TEMPERATURE FOR EACH APPLICATION.

Specifications are subject to change without notice!

CAUTION! All thermostatic water mixing valves have limitations. They will NOT provide the desired accuracy outside of their flow capacity range. Consult the Flow Capacity Chart and DO NOT OVERSIZE. Minimum flow must be no less than indicated.



1360 Elmwood Avenue, Cranston, RI 02910 USA

Phone: 401.461.1200 Fax: 401.941.5310

Email: info@leonardvalve.com

Web Site: <http://www.leonardvalve.com>

6020-LF CABINET OPTIONS

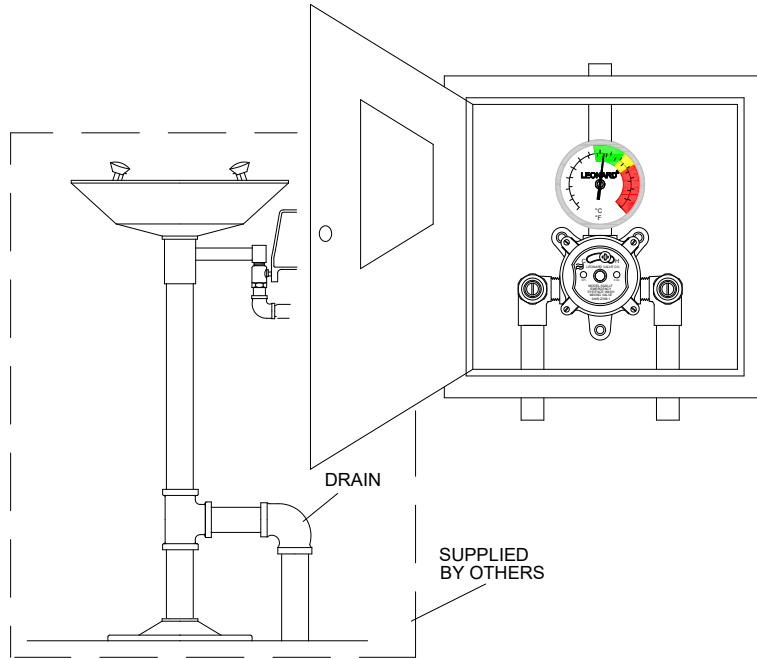

**VIEWPORT
IS
STANDARD**

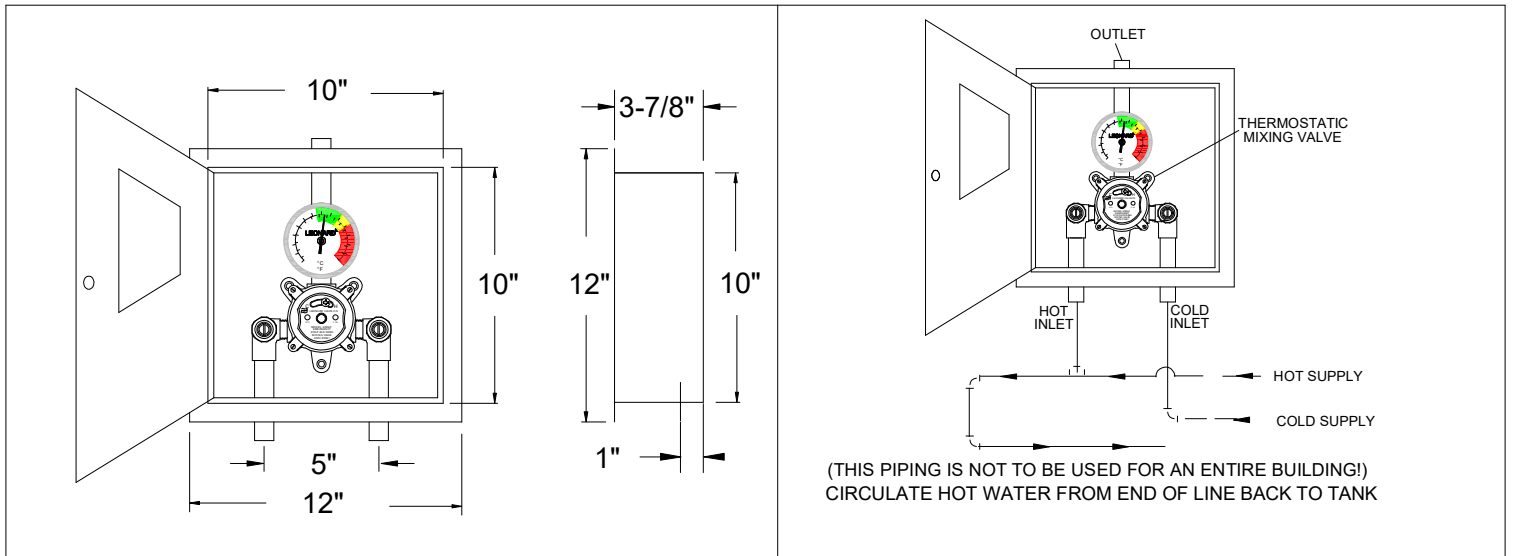

OPTIONS:

- ___ SUFFIX STSTL REC- Stainless Steel recessed cabinet
- ___ SUFFIX CP- Chrome plated finish (threaded pipe inlets & outlet)
- ___ SUFFIX TOP- Top inlets

NOTE: SUFFIX EXP- Exposed cabinets are not available,
see TA-300-STSTL-EXP

NOTE: SUFFIX BWE- Baked White is not available

NOTE: SUFFIX IT- Inlet thermometers are not available



1360 Elmwood Avenue, Cranston, RI 02910 USA

Phone: 401.461.1200 Fax: 401.941.5310

Email: info@leonardvalve.com

Web Site: <http://www.leonardvalve.com>