

THERMOSTATIC MIXING VALVE WITH THERMOMETER

370-LF-DT-ASSEMBLY

LEAD FREE THERMOSTATIC POINT OF USE MIXING VALVE WITH INSTALLED THERMOMETER

3/4" inlets, 3/4" outlet, NPT Male inlets, NPT Female outlet

MATERIALS:

- Lead free bronze body
- Locked temperature adjustment cap (vandal resistant)
- Copper encapsulated thermostat assembly with polymer thermoplastic shuttle
- Stainless steel springs
- Integral check valves on hot and cold inlets
- Minimum Flow: 0.5 GPM (1.9 l/Min) *
- Maximum Pressure: 125 PSI (8.6 BAR)
- Maximum Hot Water temperature: 200°F- (93°C)
- Approach Temperature 5°F (2.8°C) above set point.
- Temperature adjustment range, 90-140°F(32-60°C) **
- Dial thermometer included and factory assembled
- Dial thermometer range 30-250 deg F (0-120 deg C)
- Dial thermometer, 2-1/2" diameter, installed in well

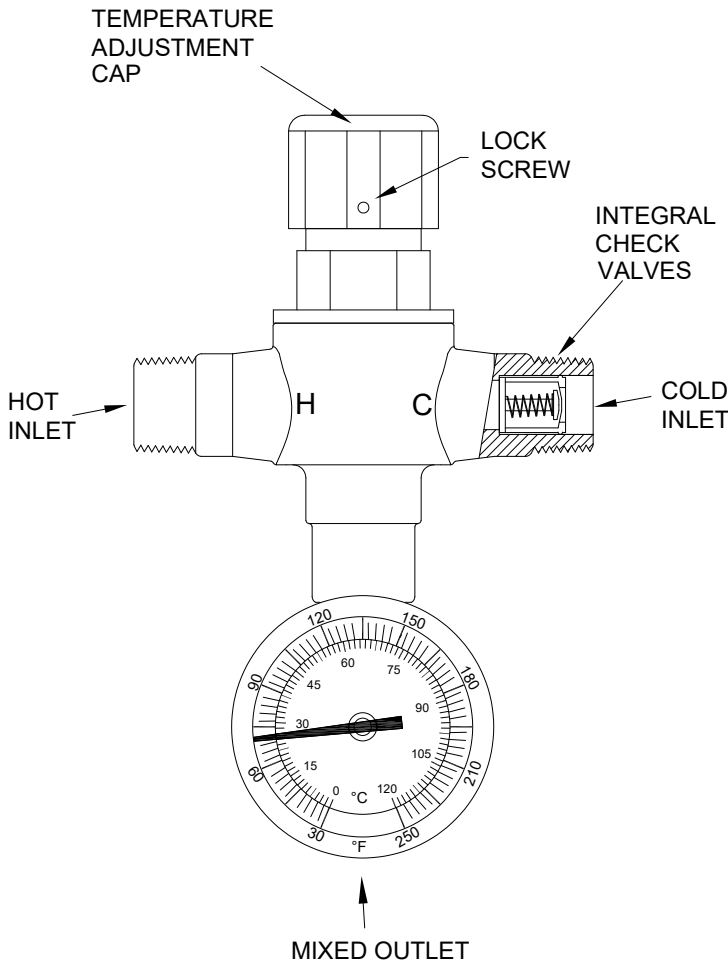

Valve only Certifications:

ASSE 1017, 1070-2015



CSA B125.70-15



Valve Meets NSF-61 Requirements

PRESSURE DROP						
5	10	20	30	40	50	PSI
.35	.70	1.4	2.1	2.8	3.4	BAR
4	6	8	10	11.5	13	GPM
15	23	30	38	44	49	l/min

This product is certified to meet Low Lead requirements of wetted surface area containing less than 0.25% lead by weight

Buy American Act
COMPLIANT

BUILD AMERICA BUY AMERICA
COMPLIANT

MADE IN THE U.S.A.

* 0.5 GPM minimum flow certified to ASSE 1070

**NOTE: For temperatures outside of this valve's stated range, please see our line of bi-metal valves.



WARNING: Risk of cancer and reproductive harm from exposure to lead – See www.P65Warnings.ca.gov

Engineer's Approval	Job # _____
	Arch/Eng. _____
	Contractor _____



1360 Elmwood Avenue, Cranston, RI 02910 USA
Phone: 401.461.1200 Fax: 401.941.5310
Email: info@leonardvalve.com
Web Site: <http://www.leonardvalve.com>